

TOIMIVUSDEKLARATSIOON

vastavalt järgmise määruse (EL) lisale III: 305/2011 (Ehitustoodete määrus)

Hilti tulekindel plokk CFS-BL

„Hilti CFS-BL“

1. Tootetüübi kordumatu identifitseerimiskood:

Hilti tulekindel plokk CFS-BL

2. Kavandatud kasutusala:

Tuletõkke- ja tihendustoode läbiviigu tihenditele, vt ETA-13/0099 (01.10.2018)

Kaablite läbiviigud	Kaablid, kaablikimbud, -rennid ja -torud, isoleeritud metalltorud
Torude läbiviigud	
Lainejuhid	

3. Tootja:

Hilti Corporation, Feldkircherstrasse 100, 9494 Schaan, Liechtensteini Vürstiriik

4. Toimivuse püsivuse hindamise ja kontrolli süsteem:

Süsteem 1

5. Euroopa hindamisdokument:

EAD-350454-00-1104 „Tuletõkke- ja tihendustoode – läbiviigutihendid“

Euroopa tehniline hinnang:

ETA-13/0099 (01.10.2018)

Tehnilise hindamise asutus:

Austrian Institute of Construction Engineering (OIB)

Teavitatud asutus(ed):

MPA Braunschweig, nr 0761

6. Deklareeritud toimivus:

Põhiomadused	Deklareeritud toimivus / ühtlustatud tehniline kirjeldus
Tuletundlikkus	Klass E vastavalt standardile EN 13501-1.
Tulepüsivus	Tulepüsivuse toimivus ja rakendusala on kooskõlas standardiga EN 13501-2. Vt lisa
Õhuläbilaskvus	Testitud vastavalt dokumendile EAD 350454-00-1104 2. Vt lisa
Kaitse müra vastu	Testitud vastavalt standardile EN ISO 140-1/2, tõlgendatud vastavalt standardile EN ISO 717-1. Vt lisa
Soojusomadused	Testitud vastavalt dokumendile EN 12667. Vt lisa
Vastupidavus ja hooldatavus	Y1 vastab standardi EAD 350454-00-1104 punktidele 2.2.9.3.4.

Eespool kirjeldatud toote toimivus vastab deklareeritud toimivusele. Käesolev toimivusdeklaratsioon on välja antud kooskõlas määrusega (EL) nr 305/2011 eespool nimetatud tootja ainuvastutusel.

Tootja poolt ja vastutusel allkirjastanud:

Dr. Christoph Aubauer
Globaalne tootejuht
Tulekaitse äriüksus
Hilti Corporation

Martin Althof
Kvaliteedijuht
Tulekaitse äriüksus
Hilti Corporation

Amendments for ETA 13-0099 (Hilti Firestop Block CFS-BL, Hilti Firestop Block)

Dear Customer,

unfortunately, there are some misleading information's in this technical document, which are addressed and will be corrected immediately in the next extension of the ETA 13-0099:

- A.) Misleading Information on page 12 of 30 of this ETA, point C.1.2 the steel profil has to be installed in way that one leg can be fixed against the sandwich panel wall as described in C.1.2 and the other leg project into the wall, like this marked in red:

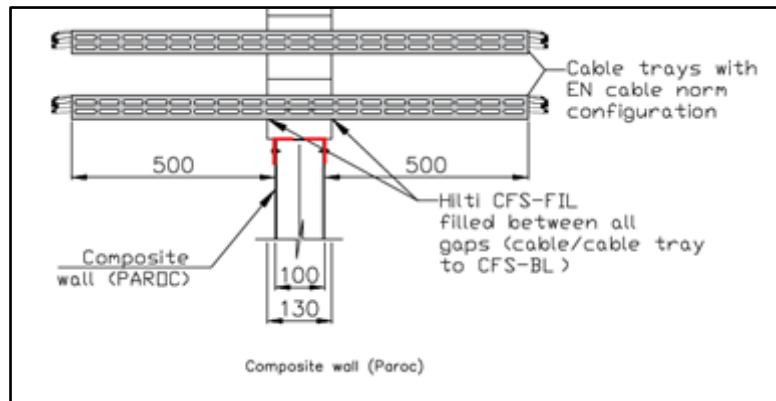

- B.) Misleading Information on page 12 of 30 of this ETA, point C.1.2 the penetration seal depth is as you can see in the illustration before, 130mm.
- C.) Misleading Information on page 16 of 30, point C.1.4 'Distance Requirements'. All minimum Distances from a penetration in a sandwich panel wall must have a minimum distance to the supporting construction of 50 mm, like her encircled in red:

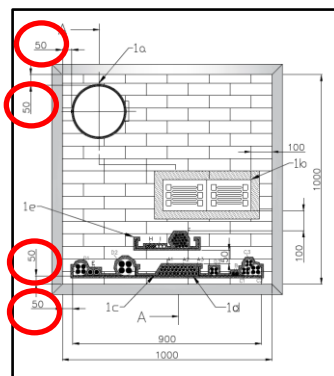

Dr. Christoph Aubauer
Global Product Manager
Business Unit Fire Protection
Hilti Corporation

Martin Althof
Head of Quality
Business Unit Fire Protection
Hilti Corporation

Intended use

“Hilti Firestop Block CFS-BL” is intended to be used as a mixed penetration seal to temporarily or permanently reinstate the fire resistance performance of flexible wall constructions, rigid wall constructions and rigid floor constructions where they have been provided with apertures which are penetrated by various cables, conduits, metal pipes, plastic pipes and multi-layer composite pipes.

The maximum opening size of the penetration seal in wall constructions is 1000 x 1000 mm, in floor constructions 1000 x 700 mm. For more details see Annex C of the ETA.

“Hilti Firestop Block CFS-BL” was also tested in a sandwich panel construction.

“Hilti Firestop Block CFS-BL” can only be used as penetration seal for cables, metal pipes, plastic pipes or for mixed penetration (combination). Further details are given in Annex C of the ETA. Other parts or service support constructions shall not penetrate the penetration seal.

“Hilti Firestop Block CFS-BL” can be installed only in types of separating elements as specified in following table. For further details see Annex C of the ETA.

Separating element	Construction	Maximum opening size of the penetration seal (width x height)
Flexible walls	<ul style="list-style-type: none"> > Steel studs or timber studs lined on both faces with minimum 2 layers of boards (minimum thickness 12,5 mm) according to EN 520 type F > For steel stud walls the space between lining must not be completely filled with insulation material, especially in the adjacent area of the penetration seal > For timber studs walls there must be a minimum distance of 100 mm of the penetration seal to any timber stud. The cavity between the penetration seal and stud has to be closed with minimum of 100 mm of insulation with classification A1 or A2 according to EN 13501-1 > Minimum thickness 100 mm 	<p>1000 x 1000 mm</p> <p>For details see Annex C of the ETA</p>
Sandwich panel wall	<ul style="list-style-type: none"> > Paroc® line 200 AST® F+ > Internal sheet made of polyethylene (PE) coated zincified steel with sheet thickness of 0,5 mm and coating thickness of 25 µm > Stone wool core with a thickness of 99 mm and a density of 115 kg/m³ > External sheet made of polyethylene (PE) coated zincified steel with sheet thickness of 0,5 mm and coating thickness of 25 µm > Minimum thickness 100 mm > Reaction to fire classification A2-s1,d0 	<p>1000 x 1000 mm</p> <p>For details see Annex C of the ETA</p>
Rigid walls	<ul style="list-style-type: none"> > Aerated concrete, concrete, masonry > Minimum density 450 kg/m³ > Minimum thickness 100 mm > The rigid wall shall be classified in accordance with EN 13501-2 for the required fire resistance period 	<p>1000 x 1000 mm</p> <p>For details see Annex C of the ETA</p>
Rigid floors	<ul style="list-style-type: none"> > Aerated concrete, concrete > Minimum density 450 kg/m³ > Minimum thickness 150 mm > The rigid floor shall be classified in accordance with EN 13501-2 for the required fire resistance period 	<p>1000 x 1000 mm</p> <p>For details see Annex C of the ETA</p>

Air permeability

The air permeability of “Hilti Firestop Block CFS-BL” was tested as blank penetration seal in an opening of 598 mm x 248 mm according to EAD 350454-00-1104 2 clause 2.2.3 by applying the test principles of EN 1026. The blocks were mounted in cross-wise, and length-wise orientation. “Hilti Firestop Filler CFS-FIL” was applied between the wall and the “Hilti Firestop Blocks CFS-BL”.

Pressure [Pa]	50	250	300	450	600
q/A air [m ³ /(h·m ²)]	Cross-wise: impermeable				
q/A air [m ³ /(h·m ²)]	Length-wise: impermeable				

Protection against noise (BWR 5)

Airborne sound insulation

The airborne sound insulation of “Hilti Firestop Block CFS-BL” was tested according to EN ISO 10140-1 and EN ISO 10140-2. The rating of the sound insulation properties has been calculated in accordance with EN ISO 717-1.

The acoustic testing was performed in a flexible wall element. The wall element was constructed from 92 mm wide metal (0,36 mm thick galvanised steel) studs spaced at 610 mm centres. The wall was clad on each side with a double layer of 16 mm thick gypsum wallboard and filled with 100 mm thick “Thermafibre” mineral wool insulation. An additional beading of 12 mm fibre cement board was applied onto the exposed side. The wall element had an area of 6,8 m². An opening of 597 x 292 mm (w x h) was filled with “Hilti Firestop Block CFS-BL” and tested as a blank penetration seal.

The reached values for the airborne sound insulation in accordance with EN ISO 717-1:1996+A1:2006 are as follows:

Component	R (C; Ctr)
Hilti Firestop Block CFS-BL	51 (1; -4)

Energy economy and heat retention (BWR 6)

Thermal properties

The thermal properties of “Hilti Firestop Block CFS-BL” were tested according to EN 12667:2001.

Component	λ_{10} in W/(m.K)
Hilti Firestop Block CFS-BL	0,089

Abbreviations used in drawings

Abbreviation	Description
A, A ₁ , A ₂ ,...	Firestop products
C, C ₁ , C ₂ ,...	Penetrating services
E, E ₁ , E ₂ ,...	Building elements (wall, floor)
h	Height/length of penetration seal
S ₁ , S ₂ , S _n	Distances
t _A	Thickness of penetration seal
t _E	Thickness of the building element
W	Max size of wall penetration
W ₁	Max size of floor penetration without support
W ₂	Max size of floor penetration with support

RESISTANCE TO FIRE CLASSIFICATION OF PENETRATION SEALS MADE OF HILTI FIRESTOP BLOCK CFS-BL

C.1 General Information

C.1.1 Wall/floor constructions

a) Flexible wall:

The wall must have a minimum thickness of 100 mm and comprise timber or steel studs lined on both faces with minimum 2 layers of 12,5 mm thick boards according to EN 520 type F.

For timber stud wall constructions there must be a minimum distance of 100 mm of the penetration seal to any stud. The cavity between stud and penetration seal must be closed with minimum of 100 mm of insulation (classification A1 or A2 in accordance with EN 13501-1).

b) Rigid wall:

The wall must have a minimum thickness of 100 mm and comprise concrete, aerated concrete or masonry, with a minimum density of 450 kg/m³.

c) Rigid floor:

The floor must have a minimum thickness of 150 mm and comprise aerated concrete or concrete with a minimum density of 450 kg/m³.

The walls / floors must be classified in accordance with EN 13501-2 for the required fire resistance period or fulfil the requirements of the relevant Eurocode.

d) Sandwich panel wall:

The partition is constructed of PAROC® line 200 AST panels with a thickness of 100 mm, a width of 1200 mm and a mineral (stone) wool core with a density of 115 kg/m³.

The sandwich panel construction must be classified in accordance with EN 13501-2 for the required fire resistance period and has to be set up according to the conditions related to the required fire resistance period. Acceptable variations in the sandwich construction are covered by the product standard EN 14509.

C.1.2 Aperture framing / beading

The penetration seal depth is always 200 mm independent of the thickness of the wall or floor. In case of walls or floors with a thickness of less than 200 mm an aperture framing or a beading has to be used.

Aperture framing: box frame of 200 mm depth perpendicular to the wall/floor surface made of gypsum or calcium silicate boards with a thickness of at least 12,5 mm, centred in the wall (figure 1a, d) / flush to the soffit of the floor.

Beading: gypsum or calcium silicate board strips with a width of at least 100 mm (w_A , figure 1e) are installed around the opening with the necessary number of layers to form a frame on the top side of a floor or two frames of the same height on both sides of a wall (figure 1b, c, e).

In walls penetration seal is installed centred (figure 1a, b), in floors flush to the soffit of the floor (figure 1c).

The penetration seals in the sandwich panel constructions do not require an aperture frame as described above. Instead, the opening perimeter is finished with 30 x 30 x 2 mm steel profiles fixed onto the panel with Ø3,5 x 30 mm self-drilling screws.

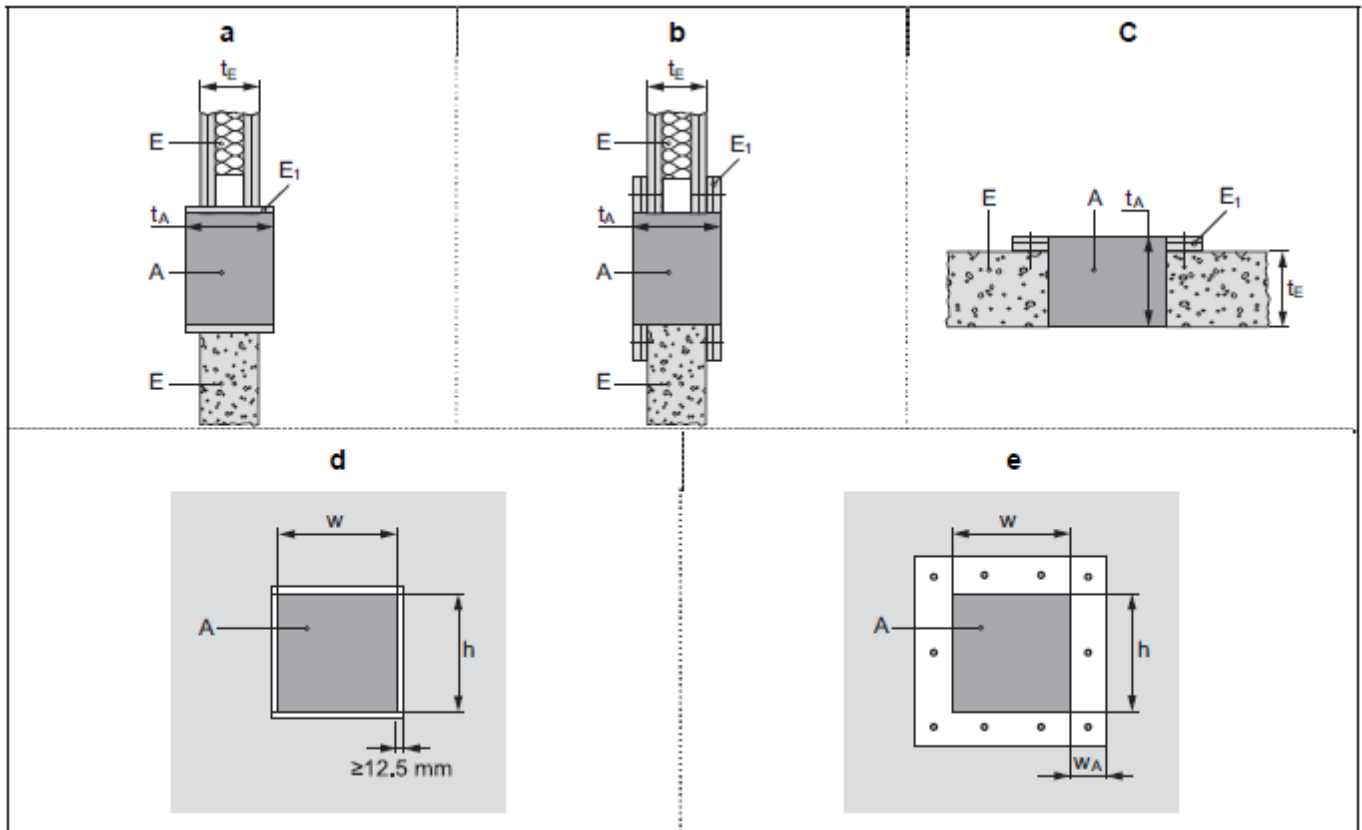

Figure 1: position of the penetration seal in walls / floors
aperture framing / beading

A	Hilti Firestop Block CFS-BL	t_E	Thickness of the separating element
E	Separating element (rigid or flexible wall construction, floor)	w	Width of the penetration seal
E1	Aperture frame	h	Height of the penetration seal
t_A	Thickness of the penetration seal	w_A	Width of the beading

C.1.3 Penetration seal types

C.1.3.1 Penetration seal type 1 (A₁) - blocks and filler

a) Services without cable supports (baskets, ladders, trays) in the area of the penetration seal

- Gaps between services and Hilti Firestop Blocks CFS-BL (A) are filled with Hilti Firestop Filler CFS-FIL (A_{1a}), depth 20 mm.

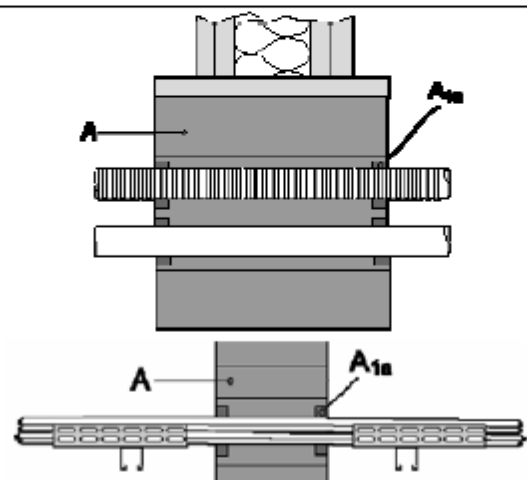

Figure 2: penetration seal type A_{1a}

b) Services on cable supports (baskets, ladders, trays) running through the penetration

- Gaps between services and Hilti Firestop Blocks CFS-BL (A) are filled with Hilti Firestop Filler CFS-FIL (A_{1b}) over the entire depth of the seal (200 mm).



Figure 3: penetration seal type A_{1b}

C.1.3.2 Penetration seal type putty 1 (A_{2a}) - blocks, filler and 1 layer putty bandage

a) Services without cable supports (baskets, ladders, trays) in the area of the penetration seal

- Gaps between services and Hilti Firestop Blocks CFS-BL (A) are filled with Hilti Firestop Filler CFS-FIL (A_{1a}), depth 20 mm.
- One layer of Hilti Firestop Putty Bandage CFS-P BA (A₂) or Hilti Firestop Bandage CFS-B is wrapped around the services or group of services.

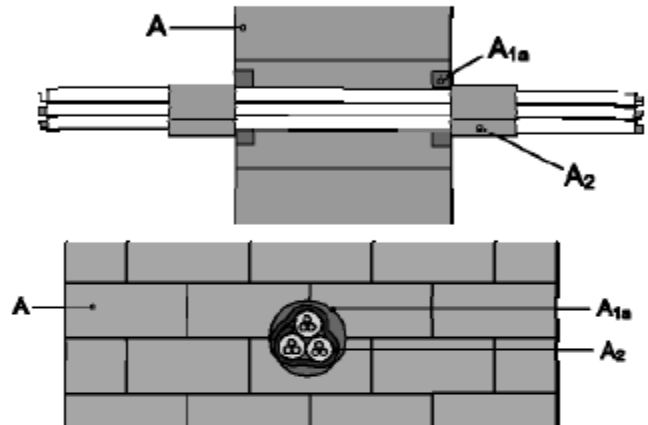

Figure 4: filler (A_{1a}) with 1 layer putty

c) Services on cable supports (baskets, ladders, trays) running through the penetration

- Gaps between services and Hilti Firestop Blocks CFS-BL (A) are filled with Hilti Firestop Filler CFS-FIL (A_{1b}) over the entire depth of the seal (200 mm).
- Services are additionally covered by a layer of Hilti Firestop Putty Bandage CFS-P BA (A_{2a}).

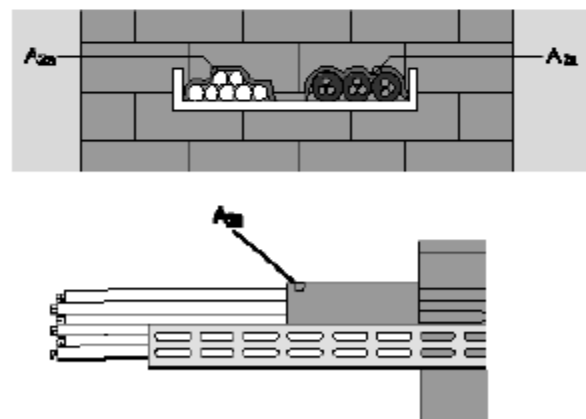

Figure 5: filler (A_{1b}) with 1 layer putty (A_{2a}), support tray

Hilti Firestop Putty Bandage CFS-P BA must be installed with the mesh outside/upside.

For floor applications, Hilti Firestop Putty Bandage CFS-P BA is required on the top side, only.

C.1.3.3 Penetration seal type putty 2 (A_{2b}) – blocks, filler and 2 layers putty bandage

a) Services without cable supports (baskets, ladders, trays) in the area of the penetration seal

- Gaps between services and Hilti Firestop Blocks CFS-BL (A) are filled with Hilti Firestop Filler CFS-FIL (A_{1a}), depth 20 mm.
- Two layers of Hilti Firestop Putty Bandage CFS-P BA (A₂) are wrapped around the services or group of services.

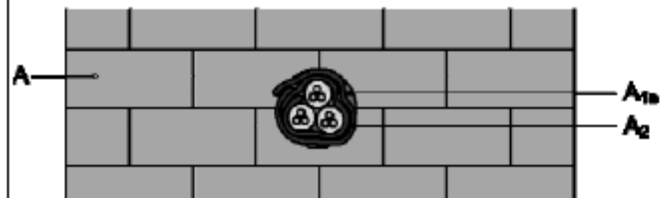
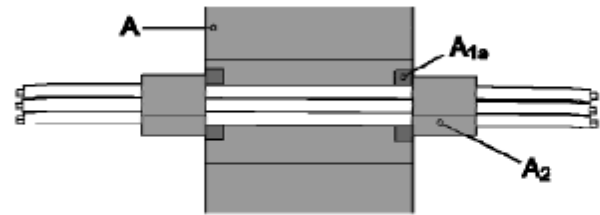

Figure 6: filler (A_{1a}) with 2 layers of putty

b) Services on cable supports (baskets, ladders, trays) running through the penetration

- Gaps between services and Hilti Firestop Blocks CFS-BL (A) are filled with Hilti Firestop Filler CFS-FIL (A_{1b}) over the entire depth of the seal (200 mm).
- Services are additionally covered by a layer of Hilti Firestop Putty Bandage CFS-P BA (A_{2a}) on top of the services in the cable supports.
- A second layer of Hilti Firestop Putty Bandage CFS-P BA (A_{2b}) is laid on top of the first and then wrapped around the services including the cable supports (A_{2b}).
- The overlap of the putty wrapping must be at least 20 mm.

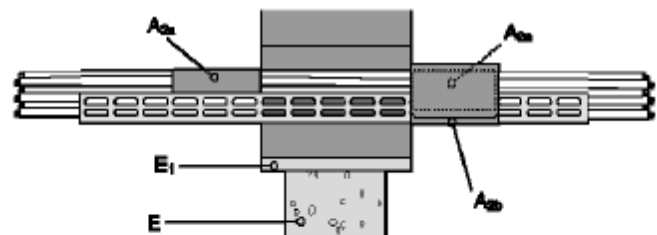
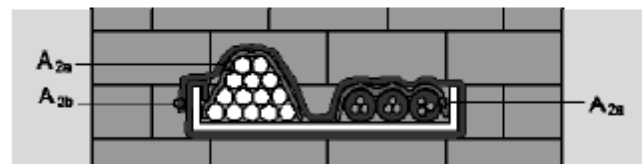

Figure 7: filler (A_{1b}) plus 2 layers of putty, support tray

Hilti Firestop Putty Bandage CFS-P BA must be installed with the mesh outside/upside.

For floor applications, Hilti Firestop Putty Bandage CFS-P BA is required on the top side, only.

C.1.4 Distance Requirements

Distances valid for installations of services in wall and floor penetrations.

Minimum distances in mm (see Figure 8):

- $s_1 = 0$ (distance between cables/cable supports and vertical seal edge)
- $s_2 = 0$ (distance between cable supports)
- $s_3 = 0$ (distance between cables and upper seal edge)
- $s_4 = 0$ (distance between cable supports and bottom seal edge)
- $s_5 = 50$ (distance between cables and cable support above)
- $s_{20} - s_{23} = 0 \text{ } \varnothing < 16 \text{ mm}$
 $= 50 \text{ } \varnothing > 16 \text{ mm}$
 (distance between conduits/waveguides to each other or to other services or seal edges)

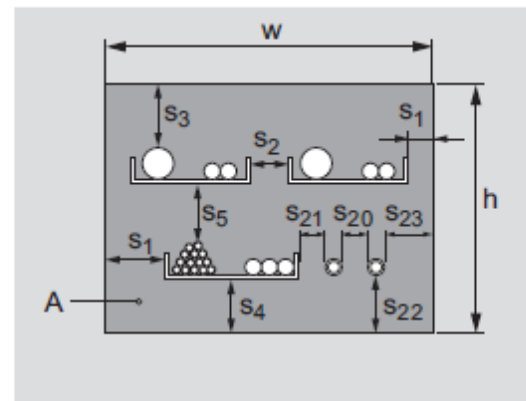

Figure 8: distances

C.2 Flexible or rigid walls according to Annex C.1.1 of the ETA - minimum wall thickness 100 mm

C.2.1 Blank seal (no services) *

Maximum seal size: 1000 x 1000 mm or an area of 10 000 cm²

Construction details (for symbols and abbreviations see Annex A.3 of the ETA):

Hilti Firestop Block CFS-BL (A) of thickness $t_A \geq 200 \text{ mm}$, centered regarding the thickness of the wall (E); aperture framing or beading (E1) according to Annex C.1.2 of the ETA.

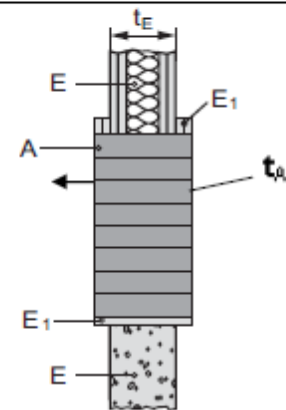

Figure 9: blank seal

Classification

EI 120

* If services are added later on in a blank seal, only the services that fulfill the required classification, listed in the tables below, may be added.

C.2.2 Penetrating services in walls – 100 mm wall thickness

Maximum seal size: 1000 x 1000 mm

Services shall be supported at maximum distance of 250 mm from both sides of wall

Abbreviation	Description	
A, A ₁ , A ₂ , ...	Firestop products: A Hilti Firestop Block CFS-BL A ₁ Hilti Firestop Filler CFS-FIL A ₂ Hilti Firestop Putty Bandage CFS-P BA	
C ₁ , C ₂ , C ₃	Penetrating services	
E, E ₁ , E ₂ , ...	Separating elements	
t _E	Thickness of the separating element	

Figure 10: wall penetration

Construction details (for symbols and abbreviations see Annex C.2.2 of the ETA):

Hilti Firestop Blocks CFS-BL (A) of thickness $t_A \geq 200$ mm, centered regarding the thickness of the wall (E); aperture framing or beading (E₁) according to Annex C.1.2 of the ETA.

Penetrating services (C₁) with or without support tray within the seal, see Figure 10 of the ETA.

Penetrating cables (C₂, C₃) with or without support tray within the seal, see Figure 10 of the ETA.

For penetrations without support trays the following seal types apply:

- Penetration seal type 1 – blocks and filler (A_{1a}) according to Annex C.1.3.1a of the ETA
- Penetration seal type putty 1 – blocks, filler and 1 layer putty bandage, according to Annex C.1.3.2a of the ETA
- Penetration seal type putty 2 – blocks, filler and 2 layers putty bandage, according to Annex C.1.3.3a of the ETA

For penetrations with support trays the following seal types apply:

- Penetration seal type 1 – blocks and filler (A_{1b}) according to Annex C.1.3.1b of the ETA
- Penetration seal type putty 1 – blocks, filler and 1 layer putty bandage, according to Annex C.1.3.2b of the ETA
- Penetration seal type putty 2 – blocks, filler and 2 layers putty bandage, according to Annex C.1.3.3b of the ETA

C.2.2.a) Cables

– All types of cables currently and commonly used in building practice in Europe (e.g. power, control, signal, telecommunication, data, optical fibre cables, with or without cable supports)

Penetration seal type:	Type 1 (Blocks + Filler)	Type Putty 1 (Blocks, Filler + 1x Putty)	Type Putty 2 (Blocks, Filler + 2x Putty)
All sheathed cables:	Classification		
$\varnothing \leq 25$ mm	EI 90 / E120	EI 90 / E120	EI 120
$25 \leq \varnothing \leq 50$ mm			
$50 \leq \varnothing \leq 80$ mm			
Tied cable bundle $\leq \varnothing 100$ mm; \varnothing single cable ≤ 21 mm	EI 120	EI 120	
Non-sheathed cables (wires) $\varnothing \leq 24$ mm	EI 60 / E120	EI 90 / E120	

C.2.2.b) Small conduits and tubes

- $\varnothing \leq 16$ mm, wall thickness ≥ 1 mm, arranged linear, with or without cables, with or without cable supports, minimum distance to each other = 0 mm

Penetration seal type:	Type 1 (Blocks + Filler)	Type Putty 1 (Blocks, Filler + 1x Putty)	Type Putty 2 (Blocks, Filler + 2x Putty)
	Classification		
Plastic conduits and tubes $\varnothing \leq 16$ mm	EI 120 U/U		
Steel conduits and tubes $\varnothing \leq 16$ mm	EI 120 U/U		

C.2.2.c) Conduits

- Hilti Firestop Blocks CFS-BL (A) of thickness $t_A \geq 200$ mm, centered regarding the thickness of the wall (E); aperture framing or beading (E_1) according to Annex C.1.2 of the ETA.
- Conduits / tubes (C_1) without support tray within the seal, see Figure 10 of the ETA.
- Wall thickness of polyolefin conduits: 1,55 to 2,30 mm
- Wall thickness of PVC conduits: 1,90 to 2,80 mm

Penetration seal type:	Type 1 (Blocks + Filler)	Type Putty 1 (Blocks, Filler + 1x Putty)	Type Putty 2 (Blocks, Filler + 2x Putty)
	Classification		
Plastic conduits:			
Hegler HP-EPKS $16 \leq \varnothing \leq 40$ mm Hegler HP-EPKMH $20 \leq \varnothing \leq 40$ mm Hegler HP-EL $16 \leq \varnothing \leq 20$ mm HFXP and HFX $25 \leq \varnothing \leq 32$ mm * HFIRM $32 \leq \varnothing \leq 40$ mm * FXPM $\varnothing = 20$ mm FXPYF $\varnothing = 32$ mm	EI 120 U/U	---	---
Bundle $\varnothing \leq 100$ mm of rigid or flexible conduits - \varnothing of single conduits ≤ 20 mm			

* In case of conduits HFIRM ($\varnothing 40$ mm) without cables inside there is no classification available, and for conduits HFX ($\varnothing 25$ mm) classification is EI 30 U/U

C.2.2.d) Waveguides (coaxial)			
<ul style="list-style-type: none"> – Hilti Firestop Blocks CFS-BL (A) of thickness $t_A \geq 200$ mm, centered regarding the thickness of the wall (E); aperture framing or beading (E_1) according to Annex C.1.2 of the ETA. – Waveguides $27,8 \text{ mm} \leq \varnothing \leq 59,9 \text{ mm}$ (C_1) without support tray within the seal, see Figure 10 of the ETA. – Additional protection: 0,7 mm thick “Hilti Firestop Coating CFS-CT” over a length of 150 mm from the surface of the penetration seal on each side of the wall. 			
Penetration seal type:	Type 1 (Blocks + Filler) <u>+ Coating</u>	Type Putty 1 (Blocks, Filler + 1x Putty)	Type Putty 2 (Blocks, Filler + 2x Putty)
Waveguides (coaxial):	Classification		
RFS Cellflex LCF 78-50 JA \varnothing 27,8 mm RFS Cellflex LCF 214-50 J \varnothing 59,9 mm RFS Heliflex HCA 78-50 JFNA \varnothing 28,0 mm RFS Heliflex HCA 158J \varnothing 59,9 mm RFS Radialflex RLKW 78-50 \varnothing 28,5 mm RFS Radialflex RLKU 158-50 JFLA \varnothing 48,2 mm	EI 120-U/C	---	---
C.2.2.e) Bus bar			
<ul style="list-style-type: none"> – Hilti Firestop Blocks CFS-BL (A) of thickness $t_A \geq 200$ mm, centered regarding the thickness of the wall (E); aperture framing or beading (E_1) according to Annex C.1.2 of the ETA. – Bus bars (C_1) with or without support tray within the seal, see Figure 10 of the ETA. 			
Penetration seal type:	Type 1 (Blocks + Filler)	Type Putty 1 (Blocks, Filler + 1x Putty)	Type Putty 2 (Blocks, Filler + 2x Putty)
	Classification		
EAE ELEKTRIK – Type: E-Line KXC 40505-B; 4000A – Maximum outer dimension of the section: 372 mm x 150 mm – Conductor material: Copper – Maximum number of conductors: 10 – Maximum section of the conductors: 140 mm x 6 mm	---	---	EI 120

C.2.2.f) Metal pipes (with insulation)			
<ul style="list-style-type: none"> – Hilti Firestop Blocks CFS-BL (A) of thickness $t_A \geq 200$ mm, centered regarding the thickness of the wall (E); aperture framing or beading (E_1) according to Annex C.1.2 of the ETA. – Metal pipes (C_1), see Figure 10 of the ETA. – Metal pipes with mineral wool insulation, minimum density 85 kg/m^3, minimum thickness 20 mm (up to $\varnothing 54$ mm) or 30 mm ($\varnothing > 54$ mm) – Additional insulation, mineral wool mat wrapped around the service, minimum density 85 kg/m^3, minimum thickness 20 mm (up to $\varnothing 54$ mm) or 40 mm ($\varnothing > 54$ mm) over a length of 300 mm (up to $\varnothing 54$ mm) or 500 mm ($\varnothing > 54$ mm) 			
Penetration seal type:	Type 1 (Blocks + Filler) + Mineral wool	Type Putty 1 (Blocks, Filler + 1x Putty)	Type Putty 2 (Blocks, Filler + 2x Putty)
Mineral wool insulated metal pipes:	Classification		
Copper pipes, up to $\varnothing 54$ mm, wall thickness 1,0/1,5 mm ³ – 14,2 ⁴ mm, insulation LS mineral wool, minimum length 1200 mm or CS	EI 120 C/U	---	---
Steel pipes, up to $\varnothing 114$ mm, wall thickness 1,0/2,0 ⁵ mm – 14,2 ⁴ mm, insulation LS mineral wool, minimum length 1200 mm (up to $\varnothing 54$ mm) or 1800 mm ($\varnothing > 54$ mm), or CS	EI 120 C/U	---	---
Steel pipes, up to $\varnothing 159$ mm, wall thickness 2,0 mm – 14,2 mm ⁴ , insulation LS mineral wool, with minimum length 1800 mm	EI 60 C/U E 120 C/U	---	---

³ Interpolation of minimum pipe wall thickness between 1,0 mm for diameter 28 mm and 1,5 mm for 54 mm for pipe diameters in between. In accordance with prEN 1366-3:2016 the results are also valid for pipe diameters < 28 mm

⁴ 14,2 mm is the maximum value covered by the rules in the EN 1366-3. This value may be limited by the particular pipe dimensions available in practice.

⁵ Interpolation of minimum pipe wall thickness between 1,0 mm for diameter 28 mm (Cu pipe) and 2,0 mm for 114 mm for pipe diameters in between. In accordance with prEN 1366-3:2016 the results are also valid for pipe diameters < 28 mm

- Hilti Firestop Blocks CFS-BL (A) of thickness $t_A \geq 200$ mm, centered regarding the thickness of the wall (E); aperture framing or beading (E_1) according to Annex C.1.2 of the ETA.
- Metal pipes (C_1), see Figure 10 of the ETA.
- Metal pipes with flexible elastomeric foam insulation according to EN 14304, thickness 8,5 to 43 mm.
- Additional insulation, Armaflex mat wrapped around the service, thickness 19 mm, over a length of 300 mm or 500 mm

Penetration seal type:	Type 1 (Blocks + Filler) + <u>Armaflex</u>	Type Putty 1 (Blocks, Filler + 1x Putty)	Type Putty 2 (Blocks, Filler + 2x Putty)
Elastomeric foam insulated metal pipes:	Classification		
Copper pipes, up to \varnothing 54 mm, wall thickness 1,0/1,5 mm ³ – 14,2 mm ⁴ , Armaflex insulation CS, thickness 8,5 – 43 mm ⁶	EI 120 C/U	---	---
Steel pipes, up to \varnothing 114 mm, wall thickness 1,0/2,0 ⁵ mm – 14,2 ⁴ mm, Armaflex insulation CS, thickness 8,5 – 43 mm ⁷	EI 90 C/U E 120 C/U	---	---

- Hilti Firestop Blocks CFS-BL (A) of thickness $t_A \geq 200$ mm, centered regarding the thickness of the wall (E); aperture framing or beading (E_1) according to Annex C.1.2 of the ETA.
- Metal pipes (C_1), see Figure 10 of the ETA.
- Metal pipes with flexible elastomeric foam insulation according to EN 14304, thickness 8,5 to 43 mm.
- Additional insulation, mineral wool mat wrapped around the service, minimum density 85 kg/m³, minimum thickness 40 mm over a length of 500 mm.

Penetration seal type:	Type 1 (Blocks + Filler) + <u>Mineral wool</u>	Type Putty 1 (Blocks, Filler + 1x Putty)	Type Putty 2 (Blocks, Filler + 2x Putty)
Elastomeric foam insulated metal pipes:	Classification		
Steel pipes, \varnothing 159 mm, wall thickness 2,0 mm – 14,2 mm ⁴ , insulation CS Armaflex, thickness 19 mm	EI 90 C/U E 120 C/U	---	---

The field of application given above for copper pipes is also valid for other metal pipes with lower heat conductivity than copper and a melting point of minimum 1100°C, e.g. unalloyed steel, low alloyed steel, cast iron, stainless steels, Ni alloys (NiCu, NiCr and NiMo alloys) and Ni.

The field of application given above for steel pipes is also valid for other metal pipes with lower heat conductivity than unalloyed steel and a melting point of minimum 1100°C, e.g. low alloyed steel, cast iron, stainless steels, Ni alloys (NiCu, NiCr and NiMo alloys)

⁶ Interpolation of insulation thickness 8,5/9 mm and 38 mm for pipe diameter 28 mm and 54 mm for insulation thicknesses and pipe diameters in between.

⁷ Interpolation of insulation thickness 8,5/15 mm and 38/43 mm for pipe diameter 28 mm (Cu pipe) and 114 mm for insulation thicknesses and pipe diameters in between.

C.3 Flexible or rigid walls according to Annex C.1.1 of the ETA - minimum wall thickness 130 mm

C.3.1 Penetrating services (single, multiple)

Construction details (for symbols and abbreviations see Annex C.2.2 of the ETA):

Hilti Firestop Blocks CFS-BL (A) of thickness $t_A \geq 200$ mm, centered regarding the thickness of the wall (E); aperture framing or beading (E_1) according to Annex C.1.2 of the ETA.

Penetrating services (C_1) with or without support tray within the seal, see Figure 10 of the ETA.

Penetrating cables (C_2 , C_3) with or without support tray within the seal, see Figure 10 of the ETA.

For penetrations without support trays the following seal types apply:

- Penetration seal type 1 – blocks and filler (A_{1a}) according to Annex C.1.3.1a of the ETA
- Penetration seal type putty 1 – blocks, filler and 1 layer putty bandage, according to Annex C.1.3.2a of the ETA
- Penetration seal type putty 2 – blocks, filler and 2 layer putty bandage, according to Annex C.1.3.3a of the ETA

For penetrations with support trays the following seal types apply:

- Penetration seal type 1 – blocks and filler (A_{1b}) according to Annex C.1.3.1b of the ETA
- Penetration seal type putty 1 – blocks, filler and 1 layer putty bandage, according to Annex C.1.3.2b of the ETA
- Penetration seal type putty 2 – blocks, filler and 2 layers putty bandage, according to Annex C.1.3.3b of the ETA

Services shall be supported at maximum 250 mm away from both faces of wall constructions.

Maximum seal size: 1000 x 1000 mm

C.3.1.1 Cables

– All types of cables currently and commonly used in building practice in Europe (e.g. power, control, signal, telecommunication, data, optical fibre cables, with or without cable supports)

Penetration seal type:	Type 1 (Blocks + Filler)	Type Putty 1 (Blocks, Filler + 1x Putty)	Type Putty 2 (Blocks, Filler + 2x Putty)
All sheathed cables:	Classification		
$\varnothing \leq 25$ mm	EI 90 / E120	EI 120	EI 120
$25 \leq \varnothing \leq 50$ mm			
$50 \leq \varnothing \leq 80$ mm	EI 90 / E120	EI 90 / E120	
Tied cable bundle $\leq \varnothing 100$ mm; \varnothing single cable ≤ 21 mm	EI 120	EI 120	
Non-sheathed cables (wires) $\varnothing \leq 24$ mm	EI 60 / E120	EI 90 / E120	

C.4 Sandwich panel partitions according to Annex C.1.1 of the ETA - minimum wall thickness 100 mm

C.4.1 Penetrating services (single, multiple)

Construction details (for symbols and abbreviations see Annex C.2.2 of the ETA):

Hilti Firestop Blocks CFS-BL (A) of thickness $t_A \geq 200$ mm, centered regarding the thickness of the wall (E); aperture framing or beading (E_1) according to Annex C.1.2 of the ETA.

For penetrations without support trays the following seal types apply:

- Penetration seal type putty 2 – blocks, filler and 2 layer putty bandage, according to Annex C.1.3.3a of the ETA

For penetrations with support trays the following seal types apply:

- Penetration seal type putty 2 – blocks, filler and 2 layers putty bandage, according to Annex C.1.3.1b of the ETA

Services shall be supported at maximum 250 mm away from both faces of wall constructions.

Maximum seal size: 1000 x 1000 mm

C.4.1.1 Cables

- All types of cables currently and commonly used in building practice in Europe (e.g. power, control, signal, telecommunication, data, optical fibre cables, with or without cable supports)
- Penetrating cables (C_2) without support tray within the seal, see Figure 10 of the ETA.

Penetration seal type:	Type 1 (Blocks + Filler)	Type Putty 1 (Blocks, Filler + 1x Putty)	Type Putty 2 (Blocks, Filler + 2x Putty)
All sheathed cables:	Classification		
$\varnothing \leq 25$ mm	---	---	EI 90 / E 120
$25 \leq \varnothing \leq 50$ mm			
$50 \leq \varnothing \leq 80$ mm			
Tied cable bundle $\leq \varnothing 100$ mm			

C.4.1.2 Small conduits and tubes

- $\varnothing \leq 16$ mm, wall thickness ≥ 1 mm, arranged linear, with or without cables, with or without cable supports, minimum distance to each other = 0 mm
- Penetrating services (C_1) with or without support tray within the seal, see Figure 10 of the ETA.

Penetration seal type:	Type 1 (Blocks + Filler)	Type Putty 1 (Blocks, Filler + 1x Putty)	Type Putty 2 (Blocks, Filler + 2x Putty)
	Classification		
Plastic conduits and tubes $\varnothing \leq 16$ mm	---	---	EI 90 / E 120
Steel conduits and tubes $\varnothing \leq 16$ mm			

C.4.1.3 Bus bar

– Bus bars (C₁) with or without support tray within the seal, see Figure 10 of the ETA.

Penetration seal type:	Type 1 (Blocks + Filler)	Type Putty 1 (Blocks, Filler + 1x Putty)	Type Putty 2 (Blocks, Filler + 2x Putty)
	Classification		
EAE ELEKTRIK – Type: E-Line KXC 40505-B; 4000A – Maximum outer dimension of the section: 372 mm x 150 mm – Conductor material: Copper – Maximum number of conductors: 10 – Maximum section of the conductors: 140 mm x 6 mm	---	---	EI 90 / E 120

C.5 Rigid floors according to Annex C.1.1 of the ETA - minimum floor thickness 150 mm

C.5.1 Blank seal (no services) *

Maximum seal size: 1000 x 700 mm or an area of 7000 cm²

Construction details (for symbols and abbreviations see Annex A.3 of the ETA):

Hilti Firestop Blocks CFS-BL (A) of thickness $t_A \geq 200$ mm, flush with the soffit of the floor (E); aperture framing or beading (E₁) according to Annex C.1.2 of the ETA.

Additional support construction for large seal size: metal band of 30 mm width and of 2 mm thickness.

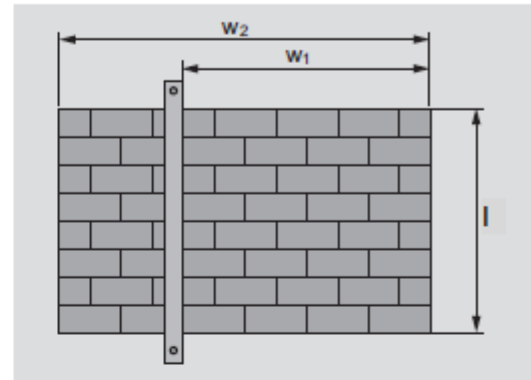

Figure 11: blank seal in floors

Blank seal measurements in floors:

without support construction ($w_2 \times l$): 1000 x 700 mm

with support construction ($w_2 \times l$): 1000 x 700 mm

without support construction ($w_1 \times l$): 500 x 700 mm

Classification

EI 60

EI 120

* If services are added later on in a blank seal only the services listed in the tables below may be added that fulfill the required classification.

C.5.2 Penetrating services in floors – 150 mm floor thickness

For floor installation maximum distance of 1st service support: 230 mm.

Abbreviation	Description
A, A ₁ , A ₂ , ...	Firestop products: A Hilti Firestop Block CFS-BL A ₁ Hilti Firestop Filler CFS-FIL A ₂ Hilti Firestop Putty Bandage CFS-P BA
C, C ₁ , C ₂ , ...	Penetrating services
E, E ₁ , E ₂ , ...	Separating elements
t _E	Thickness of the building element

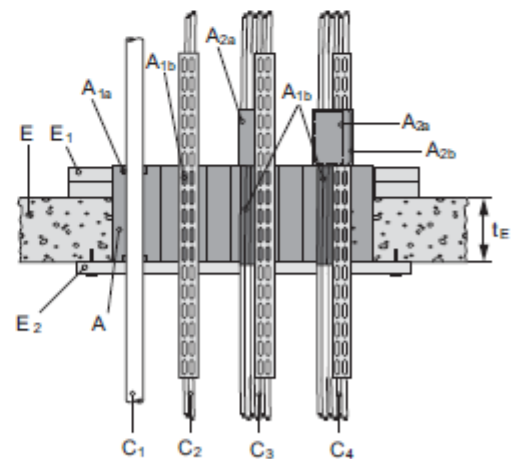

Figure 12: floor penetration

Construction details (for symbols and abbreviations see Annex C.5.2 of the ETA):

Hilti Firestop Blocks CFS-BL (A) of thickness $t_A \geq 200$ mm, flush with the soffit of the floor (E); aperture framing or beading (E₁) according to Annex C.1.2 of the ETA.

Penetrating services (C₁) with or without support tray within the seal, see Figure 12 of the ETA.

Penetrating cables (C₂, C₃, C₄) with or without support tray within the seal, see Figure 12 of the ETA.

For penetrations without support trays the following seal types apply:

- Penetration seal type 1 – blocks and filler (A_{1a}) according to Annex C.1.3.1a of the ETA
- Penetration seal type putty 1 – blocks, filler and 1 layer putty bandage, according to Annex C.1.3.2a of the ETA – on the top side only
- Penetration seal type putty 2 – blocks, filler and 2 layers putty bandage, according to Annex C.1.3.3a of the ETA – on the top side only

For penetrations with support trays the following seal types apply:

- Penetration seal type 1 – blocks and filler (A_{1b}) according to Annex C.1.3.1b of the ETA
- Penetration seal type putty 1 – blocks, filler and 1 layer putty bandage, according to Annex C.1.3.2b of the ETA – on the top side only
- Penetration seal type putty 2 – blocks, filler and 2 layers putty bandage, according to Annex C.1.3.3b of the ETA – on the top side only

C.5.2.a) Cables

– All types of cables currently and commonly used in building practice in Europe (e.g. power, control, signal, telecommunication, data, optical fibre cables, with or without cable supports)

Penetration seal type:	Type 1 (Blocks + Filler)	Type Putty 1 (Blocks, Filler + 1x Putty)	Type Putty 2 (Blocks, Filler + 2x Putty)
All sheathed cables:	Classification		
$\varnothing \leq 25$ mm	EI 90 / E120	EI 90 / E120	EI 120
$25 \leq \varnothing \leq 50$ mm			
$50 \leq \varnothing \leq 80$ mm			
Tied cable bundle $\leq \varnothing 100$ mm; \varnothing single cable ≤ 21 mm	EI 120	EI 120	
Non-sheathed cables (wires) $\varnothing \leq 17$ mm	EI 90 / E120	EI 90 / E120	
Non-sheathed cables (wires) $\varnothing \leq 24$ mm	EI 90 / E120	EI 60 / E120	

C.5.2.b) Small conduits and tubes			
<ul style="list-style-type: none"> – $\varnothing \leq 16$ mm, wall thickness ≥ 1 mm, arranged linear, with or without cables, with or without cable supports, minimum distance to each other = 0 mm – Penetrating services (C₁) with or without support tray within the seal, see Figure 12 of the ETA 			
Penetration seal type:	Type 1 (Blocks + Filler)	Type Putty 1 (Blocks, Filler + 1x Putty)	Type Putty 2 (Blocks, Filler + 2x Putty)
	Classification		
Plastic conduits and tubes $\varnothing \leq 16$ mm	EI 120 U/U	---	---
Steel conduits and tubes $\varnothing \leq 16$ mm	EI 120 C/U	---	---

C.5.2.c) Metal pipes (with insulation)			
<ul style="list-style-type: none"> – Hilti Firestop Blocks CFS-BL (A) of thickness $t_A \geq 200$ mm, flush with the soffit of the floor (E); aperture framing or beading (E₁) according to Annex C.1.2 of the ETA. – Metal pipes (C₁), see Figure 12 of the ETA. – Metal pipes with mineral wool insulation, minimum density 85 kg/m³, minimum thickness 20 mm (up to $\varnothing 54$ mm) or 30 mm ($\varnothing > 54$ mm) – Additional insulation, mineral wool mat wrapped around the service, minimum density 85 kg/m³, minimum thickness 20 mm (up to $\varnothing 54$ mm) or 40 mm ($\varnothing > 54$ mm) over a length of 300 mm (up to $\varnothing 54$ mm) or 500 mm ($\varnothing > 54$ mm) 			
Penetration seal type:	Type 1 (Blocks + Filler) <u>+ Mineral wool</u>	Type Putty 1 (Blocks, Filler + 1x Putty)	Type Putty 2 (Blocks, Filler + 2x Putty)
	Classification		
Mineral wool insulated metal pipes:			
Copper pipes, up to $\varnothing 54$ mm, wall thickness 1,0/1,5 mm ⁸ – 14,2 ⁴ mm, insulation CS mineral wool	EI 120 C/U	---	---
Steel pipes, up to $\varnothing 159$ mm, wall thickness 1,0/2,0 ⁹ mm – 14,2 ⁴ mm, insulation LS mineral wool, minimum length 1200 mm (up to $\varnothing 54$ mm) or 1800 mm ($\varnothing > 54$ mm), or CS	EI 120 C/U	---	---

⁸ Interpolation of minimum pipe wall thickness between 1,0 mm for diameter 28 mm and 1,5 mm for 54 mm for pipe diameters in between. In accordance with prEN 1366-3:2016 the results are also valid for pipe diameters < 28 mm

⁹ Minimum pipe wall thickness between 1,0 mm for diameter 28 – 54 mm (Cu pipe) and 2,0 mm for pipe diameters up to 159 mm. In accordance with prEN 1366-3:2016 the results are also valid for pipe diameters < 28 mm

<ul style="list-style-type: none"> – Hilti Firestop Blocks CFS-BL (A) of thickness $t_A \geq 200$ mm, flush with the soffit of the floor (E); aperture framing or beading (E₁) according to Annex C.1.2 of the ETA. – Metal pipes (C₁), see Figure 12 of the ETA. – Metal pipes with flexible elastomeric foam insulation according to EN 14304, thickness 8,5 to 43 mm. – Additional insulation, Armaflex mat wrapped around the service, thickness 19 mm, over a length of 300 mm or 500 mm 			
Penetration seal type:	Type 1 (Blocks + Filler) + <u>Armaflex</u>	Type Putty 1 (Blocks, Filler + 1x Putty)	Type Putty 2 (Blocks, Filler + 2x Putty)
Elastomeric foam insulated metal pipes:	Classification		
Copper pipes, up to Ø 54 mm, wall thickness 1,0/1,5 mm ³ – 14,2 mm ⁴ , Armaflex insulation CS, thickness 8,5 – 43 mm ⁶	EI 120 C/U	---	---
The field of application given above is also valid for other metal pipes with lower heat conductivity than copper and a melting point of minimum 1100°C, e.g. unalloyed steel, low alloyed steel, cast iron, stainless steels, Ni alloys (NiCu, NiCr and NiMo alloys) and Ni.			

<ul style="list-style-type: none"> – Hilti Firestop Blocks CFS-BL (A) of thickness $t_A \geq 200$ mm, flush with the soffit of the floor (E); aperture framing or beading (E₁) according to Annex C.1.2 of the ETA. – Metal pipes (C₁), see Figure 12 of the ETA. – Metal pipes with flexible elastomeric foam insulation according to EN 14304, thickness 8,5 to 43 mm. – Additional insulation, mineral wool mat wrapped around the service, thickness 30 mm, over a length of 500 mm 			
Penetration seal type:	Type 1 (Blocks + Filler) + <u>Mineral wool</u>	Type Putty 1 (Blocks, Filler + 1x Putty)	Type Putty 2 (Blocks, Filler + 2x Putty)
Elastomeric foam insulated metal pipes:	Classification		
Steel pipes, up to Ø 159 mm, wall thickness 2,0 mm – 14,2 mm ⁴ , insulation CS mineral wool, thickness 30 mm or more	EI 120 C/U	---	---
The field of application given above is also valid for other metal pipes with lower heat conductivity than unalloyed steel and a melting point of minimum 1100°C, e.g. low alloyed steel, cast iron, stainless steels, Ni alloys (NiCu, NiCr and NiMo alloys)			

- Hilti Firestop Blocks CFS-BL (A) of thickness $t_A \geq 200$ mm, flush with the soffit of the floor (E); aperture framing or beading (E1) according to Annex C.1.2 of the ETA.
- Metal pipes (C1), see Figure 12 of the ETA.
- Metal pipes with flexible elastomeric foam insulation according to EN 14304, thickness 8,5 to 43 mm.
- Additional insulation, mineral wool mat wrapped around the service, minimum density 85 kg/m³, minimum thickness 20 mm (up to \varnothing 114 mm) or 40 mm ($\varnothing > 114$ mm) over a length of 300 mm (up to \varnothing 114 mm) or 500 mm ($\varnothing > 114$ mm)
- Additional protection, 2 layer of Hilti Firestop Putty Bandage CFS-B (A₂) is wrapped around the tube with insulation.

Penetration seal type:	Type 1 (Blocks + Filler)	Type Putty 1 (Blocks, Filler + 1x Putty)	Type Putty 2 (Blocks, Filler + 2x Putty) + Mineral wool
Elastomeric foam insulated metal pipes:	Classification		
Steel pipes, up to \varnothing 114 mm, wall thickness 1,0/2,0 mm ⁵ – 14,2 mm ⁴ , insulation CS Armaflex, thickness 15 – 43 mm	---	---	EI 90 C/U E 120 C/U
Steel pipes, \varnothing 114 – 159 mm, wall thickness 2,0 mm – 14,2 mm ⁴ , insulation CS Armaflex, thickness 15 – 19 mm ¹⁰	---	---	EI 90 C/U E 120 C/U
Steel pipes, \varnothing 114 mm, wall thickness 2,0 mm – 14,2 mm ⁴ , insulation CS Armaflex, thickness 15 – 43 mm ⁶	---	---	EI 90 C/U E 120 C/U
Steel pipes, \varnothing 114 mm, wall thickness 2,0 mm – 14,2 mm ⁴ , insulation CS Armaflex, thickness 43 mm	---	---	EI 120 C/U
Steel pipes, \varnothing 159 mm, wall thickness 2,0 mm – 14,2 mm ⁴ , insulation CS Armaflex, thickness 19 mm	---	---	EI 120 C/U
The field of application given above is also valid for other metal pipes with lower heat conductivity than unalloyed steel and a melting point of minimum 1100°C, e.g. low alloyed steel, cast iron, stainless steels, Ni alloys (NiCu, NiCr and NiMo alloys)			

¹⁰ Interpolation of insulation thickness 15 mm and 19 mm for pipe diameter 114 mm and 159 mm for insulation thicknesses and pipe diameters in between.

C.6 Combination of Hilti Firestop Block CFS-BL with other Hilti Firestop products

Hilti Firestop Block CFS-BL may be combined with other Hilti Firestop products.

In cases where services are only running through the area of products used in addition, the ETA specifications of this product have to be followed.

Hilti Firestop Foam CFS-F FX	<p>a) Hilti Firestop Foam CFS-F FX is used in area without services as gap filling of upper space of penetration where otherwise a Hilti Firestop Block CFS-BL has to be cut to close the aperture of the penetration seal. Blank seal with a seal depth of 200 mm is classified EI120.</p> <p>b) Service penetrations within foam penetration seal– maximum size of foam area 400x400 mm:</p> <ul style="list-style-type: none">• Hilti Firestop Blocks CFS-BL are installed in the aperture partially for e.g. in the lower part only or• building a frame. This frame can be built also after applying the foam, around the foam seal.• Services running through the opening or the block frame are sealed with Hilti Firestop Foam CFS-F FX according to ETA-10/0109 "Hilti Firestop Foam CFS-F FX"• Distance rules are applied to seal frames (no block in between) or to block frame as in ETA 10/0109 to aperture frame or services.
Hilti Firestop Plug CFS-PL Ø 110 within a plastic sleeve	<p>Hilti Firestop Plug CFS-PL Ø 110 can be used in a wall or floor penetration sealed by Hilti Firestop Blocks CFS-BL.</p> <ul style="list-style-type: none">• The plug has to be placed in a PVC pipe sleeve (wall thickness of pipe: 2 to 6 mm) of 200 mm in length, installed flush with the block seal.• The distances to other services or edges are at least 50 mm.• The sleeve is closed by Hilti Firestop Plug CFS-PL Ø 110 on each side.• Penetrations through the plug seal are classified as documented in ETA-13/0125 "Hilti Firestop Plug CFS-PL".