

ET

## TOIMIVUSDEKLARATSIOON

vastavalt järgneva määruse (EL) lisale III: 305/2011 (Ehitustoodete määrus)

 Hilti sandwich-paneelide kruvid S-CD S, S-CDW S  
 Nr Hilti-SF-DoP-009

- 1. Tootetüübi kordumatu identifitseerimiskood:** Hilti sandwich-paneelide kinnituskruvid S-CD S, S-CDW S
- 2. Tüübi-, partii- või seerianumber või muu element, mis võimaldab ehitustoote identifitseerimist artikli 11 lõike 4 kohaselt:** tüübi- ja partii number on toodud pakendil

**3. Ehitustoote tootja poolt ette nähtud kavandatud kasutusotstarve või -otstarbed kooskõlas kohaldatava ühtlustatud tehnilise kirjeldusega:**

Üldine tüüp ja kasutusotstarve	Isepuurivad kinnituskruvid sandwich-paneelidele
Hõlmatud toodete suurus	Kruvi läbimõõt 5,5 ja 6,5
Alus ja kinnitav materjal	Teras, mis vastab standarditele EN 10025-1 ja EN 10346, Puit, mis vastab standardile EN 14081
Kinnitusvahendi materjal	Roostevaba teras (1.4301, 1.4401 või 1.4571), mis vastab standardile EN 10088
Koormus	Staatile ja poolstaatile (tuulekoormus)

**4. Artikli 11 (5) kohaselt nõutav tootja nimi, registreeritud kaubamärk või tootja registreeritud kaubamärk ja kontaktaadress:** Hilti Aktiengesellschaft, Business Unit Direct Fastening, 9494 Schaan, Fürstentum Liechtenstein

**5. Vajaduse korral volitatud esindaja nimi ja kontaktaadress, kelle volitused hõlmavad artiklis 12 (2) täpsustatud ülesandeid:** puuduvad.

**6. Lisas V sätestatud ehitustoote toimivuse püsivuse hindamise ja kontrollimise süsteem või süsteemid:** süsteem 2+

**7. Ühtlustatud standardiga hõlmatud ehitustoote toimivusdeklaratsiooni korral:** puudub.

**8. Sellise ehitustoote, mille kohta on antud Euroopa tehniline hinnang, toimivusdeklaratsiooni korral:** Deutsches Institut für Bautechnik (DIBt) andis välja ETA-13-0179 dokumendi EAD 330047-01-0602 alusel. Teavitatud asutus MPA-Karlsruhe 0769 viis läbi kolmanda osapoole ülesanded süsteemi 2+ all ja väljastas tootmisjuhtimise vastavusdeklaratsiooni 0769-CPR-VAS-00705.

**9. Deklareeritud toimivus:**

Põhiomadused	Toimivus	Ühtlustatud tehniline kirjeldus
Iseloomulik pingetaluvus $N_{R,k}$	Lisa 1-16 ETA-13/0179 (lisa 8-11, 16-27)	ETA 13/0179 EAD 330047-01-0602
Iseloomulik nihketugevus $V_{R,k}$		
Max lubatud kruvipea väljasurve $u$		
Rakendamise piirväärtused		
Tuletundlikkus	A1	

**10. Punktides 1 ja 2 kindlaksmääratud toote toimivus on kooskõlas punktis 9 osutatud deklareeritud toimivusega. Käesolev toimivusdeklaratsioon on välja antud punktis 4 kindlaksmääratud tootja ainuvastutusel.**

Tootja eest ja nimel allkirjastanud:

**Lars Taenzer**  
 Head of Business Unit Direct Fastening  
 Hilti Aktiengesellschaft, Schaan, 01.05.2019

**Pierre Hohmeier**  
 Head of Quality Screw Fastening

Annex 1:  
ETA-13/0179, Annex 8

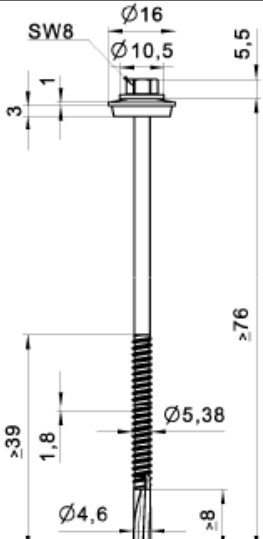

**Material:**  
 Fastener: stainless Steel (1.4301, 1.4401, 1.4571) - EN 10088  
 Washer: stainless Steel (1.4301) - EN 10088  
 Component I: S280GD, S320GD, S350GD, S390GD, S420GD, S450GD - EN 10346  
 Component II: S235, S275, S355, S420 - EN 10025-1  
 S280GD, S320GD, S350GD, S390GD, S420GD, S450GD - EN 10346

**Drilling capacity:**  $\Sigma t_i \leq 6,00$  mm

**Timber substructures:**  
no performance determined

$t_{N1}, t_{N2}, d, D$ [mm]	$t_{ii}$ [mm]									
	1,50	2,00	2,50	3,00	4,00	5,00	6,00	8,00	≥ 10,0	
$V_{R,k}$ [kN]	0,40	0,65	0,65	0,65	0,65	0,65	0,65	—	—	—
	0,50	1,17	1,17	1,17	1,17	1,17	1,17	—	—	—
	0,55	1,36	1,36	1,36	1,36	1,36	1,36	—	—	—
	0,60	1,54	1,54	1,54	1,54	1,54	1,54	—	—	—
	0,63	1,65	1,65	1,65	1,65	1,65	1,65	—	—	—
	0,75	2,03	2,03	2,03	2,03	2,03	2,03	—	—	—
	0,88	2,40	2,40	2,40	2,40	2,40	2,40	—	—	—
	1,00	2,68	2,68	2,68	2,68	2,68	2,68	—	—	—
$N_{R,k}$ [kN]	0,40	—	—	—	—	—	—	—	—	—
	0,50	1,80	1,92	1,92	1,92	1,92	1,92	—	—	—
	0,55	1,80	2,19	2,19	2,19	2,19	2,19	—	—	—
	0,60	1,80	2,48	2,48	2,48	2,48	2,48	—	—	—
	0,63	1,80	2,65	2,65	2,65	2,65	2,65	—	—	—
	0,75	1,80	2,80	3,57	3,57	3,57	3,57	—	—	—
	0,88	1,80	2,80	3,57	3,57	3,57	3,57	—	—	—
	1,00	1,80	2,80	3,57	3,57	3,57	3,57	—	—	—
$u$ [mm]	40	18,0	8,0	7,0	6,0	5,0	3,0	—	—	—
	50	22,0	10,5	9,0	7,5	6,5	4,3	—	—	—
	60	26,0	13,0	11,0	9,0	8,0	5,5	—	—	—
	70	29,5	16,5	14,0	12,0	11,5	6,8	—	—	—
	80	33,0	20,0	17,5	15,0	14,0	8,0	—	—	—
	100	33,0	20,0	17,5	15,0	14,0	10,0	—	—	—
	120	33,0	20,0	17,5	15,0	14,0	12,0	—	—	—
	≥ 140	33,0	20,0	17,5	15,0	14,0	14,0	—	—	—
$N_{R,k,II}$ [kN]	1,94	2,84	3,83	4,89	7,18	7,18	—	—	—	

If component  $t_{N1}$  resp.  $t_{N2}$  is made of steel grade higher than S280GD the grey highlighted values may be increased by 8,3%. If both components  $t_{N1}$  resp.  $t_{N2}$  and  $t_{ii}$  are made of steel grade higher than S280GD all values  $V_{R,k}$  and  $N_{R,k}$  may be increased by 8,3%. If component  $t_{ii}$  is made of steel grade higher than S235 or S280GD the values  $N_{R,k,II}$  may be increased by 8,3%.

Self drilling screw	Annex 8
Hilti S-CDH 53 S 5,5 x L Hilti S-CDH 53 SS 5,5 x L with hexagon head and sealing washer Ø16 mm	

Annex 2:  
ETA-13/0179, Annex 9

**Material:**  
 Fastener: stainless Steel (1.4301, 1.4401, 1.4571) - EN 10088  
 Washer: stainless Steel (1.4301) - EN 10088  
 Component I: S280GD, S320GD, S350GD, S390GD, S420GD, S450GD - EN 10346  
 Component II: S235, S275, S355, S420 - EN 10025-1, S280GD, S320GD, S350GD, S390GD, S420GD, S450GD - EN 10346

**Drilling capacity:**  $\Sigma t_i \leq 6,00$  mm

**Timber substructures:**  
no performance determined

$t_{N1}, t_{N2}, d, D$ [mm]	$t_i$ [mm]									
	1,50	2,00	2,50	3,00	4,00	5,00	6,00	8,00	≥ 10,0	
$V_{R,k}$ [kN]	0,40	0,65	0,65	0,65	0,65	0,65	0,65	—	—	—
	0,50	1,17	1,17	1,17	1,17	1,17	1,17	—	—	—
	0,55	1,36	1,36	1,36	1,36	1,36	1,36	—	—	—
	0,60	1,54	1,54	1,54	1,54	1,54	1,54	—	—	—
	0,63	1,65	1,65	1,65	1,65	1,65	1,65	—	—	—
	0,75	2,03	2,03	2,03	2,03	2,03	2,03	—	—	—
	0,88	2,40	2,40	2,40	2,40	2,40	2,40	—	—	—
	1,00	2,68	2,68	2,68	2,68	2,68	2,68	—	—	—
	$N_{R,k}$ [kN]	0,40	—	—	—	—	—	—	—	—
0,50		1,80	2,60	2,60	2,60	2,60	2,60	—	—	—
0,55		1,80	2,80	3,00	3,00	3,00	3,00	—	—	—
0,60		1,80	2,80	3,25	3,25	3,25	3,25	—	—	—
0,63		1,80	2,80	3,40	3,40	3,40	3,40	—	—	—
0,75		1,80	2,80	3,80	4,20	4,20	4,20	—	—	—
0,88		1,80	2,80	3,80	4,50	4,50	4,50	—	—	—
1,00		1,80	2,80	3,80	4,50	4,50	4,50	—	—	—
$u$ [mm]		40	18,0	8,0	7,0	6,0	5,0	3,0	—	—
	50	22,0	10,5	9,0	7,5	6,5	4,3	—	—	—
	60	26,0	13,0	11,0	9,0	8,0	5,5	—	—	—
	70	29,5	16,5	14,0	12,0	11,5	6,8	—	—	—
	80	33,0	20,0	17,5	15,0	14,0	8,0	—	—	—
	100	33,0	20,0	17,5	15,0	14,0	10,0	—	—	—
	120	33,0	20,0	17,5	15,0	14,0	12,0	—	—	—
	≥ 140	33,0	20,0	17,5	15,0	14,0	14,0	—	—	—
$N_{R,k,II}$ [kN]	1,94	2,84	3,83	4,89	7,18	7,18	—	—	—	

If component  $t_{N1}$  resp.  $t_{N2}$  is made of steel grade higher than S280GD the grey highlighted values may be increased by 8,3%. If both components  $t_{N1}$  resp.  $t_{N2}$  and  $t_i$  are made of steel grade higher than S280GD all values  $V_{R,k}$  and  $N_{R,k}$  may be increased by 8,3%. If component  $t_i$  is made of steel grade higher than S235 or S280GD the values  $N_{R,k,II}$  may be increased by 8,3%.

Self drilling screw	Annex 9
Hilti S-CDH 63 S 5,5 x L Hilti S-CDH 63 SS 5,5 x L Hilti S-CDH 73 S 5,5 x L Hilti S-CDH 73 SS 5,5 x L with hexagon head and sealing washer $\geq \text{Ø}19$ mm	

Annex 3:  
ETA-13/0179, Annex 10

**Material:**  
 Fastener: stainless Steel (1.4301, 1.4401, 1.4571) - EN 10088  
 Washer: stainless Steel (1.4301) - EN 10088  
 Component I: S280GD, S320GD, S350GD, S390GD, S420GD, S450GD - EN 10346  
 Component II: S235, S275, S355, S420 - EN 10025-1, S280GD, S320GD, S350GD, S390GD, S420GD, S450GD - EN 10346

**Drilling capacity:**  $\Sigma t_i \leq 6,00$  mm

**Timber substructures:**  
no performance determined

$t_{N1}, t_{N2}, d, D$ [mm]	$t_{II}$ [mm]									
	1,50	2,00	2,50	3,00	4,00	5,00	6,00	8,00	≥ 10,0	
$V_{R,k}$ [kN]	0,40	0,65	0,65	0,65	0,65	0,65	0,65	—	—	—
	0,50	1,17	1,17	1,17	1,17	1,17	1,17	—	—	—
	0,55	1,36	1,36	1,36	1,36	1,36	1,36	—	—	—
	0,60	1,54	1,54	1,54	1,54	1,54	1,54	—	—	—
	0,63	1,65	1,65	1,65	1,65	1,65	1,65	—	—	—
	0,75	2,03	2,03	2,03	2,03	2,03	2,03	—	—	—
	0,88	2,40	2,40	2,40	2,40	2,40	2,40	—	—	—
	1,00	2,68	2,68	2,68	2,68	2,68	2,68	—	—	—
$N_{R,k}$ [kN]	0,40	—	—	—	—	—	—	—	—	—
	0,50	1,80	1,92	1,92	1,92	1,92	1,92	—	—	—
	0,55	1,80	2,19	2,19	2,19	2,19	2,19	—	—	—
	0,60	1,80	2,48	2,48	2,48	2,48	2,48	—	—	—
	0,63	1,80	2,65	2,65	2,65	2,65	2,65	—	—	—
	0,75	1,80	2,80	3,57	3,57	3,57	3,57	—	—	—
	0,88	1,80	2,80	3,57	3,57	3,57	3,57	—	—	—
	1,00	1,80	2,80	3,57	3,57	3,57	3,57	—	—	—
$u$ [mm]	40	18,0	8,0	7,0	6,0	5,0	3,0	—	—	—
	50	22,0	10,5	9,0	7,5	6,5	4,3	—	—	—
	60	26,0	13,0	11,0	9,0	8,0	5,5	—	—	—
	70	29,5	16,5	14,0	12,0	11,5	6,8	—	—	—
	80	33,0	20,0	17,5	15,0	14,0	8,0	—	—	—
	100	33,0	20,0	17,5	15,0	14,0	10,0	—	—	—
	120	33,0	20,0	17,5	15,0	14,0	12,0	—	—	—
≥ 140	33,0	20,0	17,5	15,0	14,0	14,0	—	—	—	
$N_{R,k,II}$ [kN]	1,94	2,84	3,83	4,89	7,18	7,18	—	—	—	

If component  $t_{N1}$  resp.  $t_{N2}$  is made of steel grade higher than S280GD the grey highlighted values may be increased by 8,3%. If both components  $t_{N1}$  resp.  $t_{N2}$  and  $t_{II}$  are made of steel grade higher than S280GD all values  $V_{R,k}$  and  $N_{R,k}$  may be increased by 8,3%. If component  $t_{II}$  is made of steel grade higher than S235 or S280GD the values  $N_{R,k,II}$  may be increased by 8,3%.

Self drilling screw	Annex 10
Hilti S-CD 53 S 5,5 x L Hilti S-CD 53 SS 5,5 x L with hexagon head and sealing washer Ø16 mm	

Annex 4:  
ETA-13/0179, Annex 11

**Material:**  
Fastener: stainless Steel (1.4301, 1.4401, 1.4571) - EN 10088  
Washer: stainless Steel (1.4301) - EN 10088  
Component I: S280GD, S320GD, S350GD, S390GD, S420GD, S450GD - EN 10346  
Component II: S235, S275, S355, S420 - EN 10025-1, S280GD, S320GD, S350GD, S390GD, S420GD, S450GD - EN 10346

**Drilling capacity:**  $\Sigma t_i \leq 6,00$  mm

**Timber substructures:**  
no performance determined

$t_{N1}, t_{N2}, d, D$ [mm]	$t_i$ [mm]									
	1,50	2,00	2,50	3,00	4,00	5,00	6,00	8,00	$\geq 10,0$	
$V_{R,k}$ [kN]	0,40	0,65	0,65	0,65	0,65	0,65	0,65	—	—	—
	0,50	1,17	1,17	1,17	1,17	1,17	1,17	—	—	—
	0,55	1,36	1,36	1,36	1,36	1,36	1,36	—	—	—
	0,60	1,54	1,54	1,54	1,54	1,54	1,54	—	—	—
	0,63	1,65	1,65	1,65	1,65	1,65	1,65	—	—	—
	0,75	2,03	2,03	2,03	2,03	2,03	2,03	—	—	—
	0,88	2,40	2,40	2,40	2,40	2,40	2,40	—	—	—
	1,00	2,68	2,68	2,68	2,68	2,68	2,68	—	—	—
$N_{R,k}$ [kN]	0,40	—	—	—	—	—	—	—	—	—
	0,50	1,80	2,60	2,60	2,60	2,60	2,60	—	—	—
	0,55	1,80	2,80	3,00	3,00	3,00	3,00	—	—	—
	0,60	1,80	2,80	3,25	3,25	3,25	3,25	—	—	—
	0,63	1,80	2,80	3,40	3,40	3,40	3,40	—	—	—
	0,75	1,80	2,80	3,80	4,20	4,20	4,20	—	—	—
	0,88	1,80	2,80	3,80	4,50	4,50	4,50	—	—	—
	1,00	1,80	2,80	3,80	4,50	4,50	4,50	—	—	—
$u$ [mm]	40	18,0	8,0	7,0	6,0	5,0	3,0	—	—	—
	50	22,0	10,5	9,0	7,5	6,5	4,3	—	—	—
	60	26,0	13,0	11,0	9,0	8,0	5,5	—	—	—
	70	29,5	16,5	14,0	12,0	11,5	6,8	—	—	—
	80	33,0	20,0	17,5	15,0	14,0	8,0	—	—	—
	100	33,0	20,0	17,5	15,0	14,0	10,0	—	—	—
	120	33,0	20,0	17,5	15,0	14,0	12,0	—	—	—
	$\geq 140$	33,0	20,0	17,5	15,0	14,0	14,0	—	—	—
$N_{R,k,II}$ [kN]	1,94	2,84	3,83	4,89	7,18	7,18	—	—	—	

If component  $t_{N1}$  resp.  $t_{N2}$  is made of steel grade higher than S280GD the grey highlighted values may be increased by 8,3%. If both components  $t_{N1}$  resp.  $t_{N2}$  and  $t_i$  are made of steel grade higher than S280GD all values  $V_{R,k}$  and  $N_{R,k}$  may be increased by 8,3%. If component  $t_i$  is made of steel grade higher than S235 or S280GD the values  $N_{R,k,II}$  may be increased by 8,3%.

Self drilling screw	Annex 11
Hilti S-CD 63 S 5,5 x L Hilti S-CD 63 SS 5,5 x L Hilti S-CD 73 S 5,5 x L Hilti S-CD 73 SS 5,5 x L with hexagon head and sealing washer $\geq \varnothing 19$ mm	

Annex 5:  
ETA-13/0179, Annex 16

**Material:**  
 Fastener: stainless Steel (1.4301, 1.4401, 1.4571) - EN 10088  
 Washer: stainless Steel (1.4301) - EN 10088  
 Component I: S280GD, S320GD, S350GD - EN 10346  
 Component II: S235 - EN 10025-1  
 S280GD, S320GD - EN 10346

**Drilling capacity:**  $\Sigma t_i \leq 12,00$  mm

**Timber substructures:**  
no performance determined

$t_{N1}, t_{N2}, d, D$ [mm]	$t_{II}$ [mm]									
	3,00	4,00	5,00	6,00	8,00	9,00	10,0	11,0	$\geq 12,0$	
$V_{R,k}$ [kN]	0,40	0,99	0,99	0,99	0,99	0,99	0,99	0,99	0,99	—
	0,50	1,46	1,46	1,46	1,46	1,46	1,46	1,46	1,46	—
	0,55	1,62	1,62	1,62	1,62	1,62	1,62	1,62	1,62	—
	0,60	1,80	1,80	1,80	1,80	1,80	1,80	1,80	1,80	—
	0,63	1,90	1,90	1,90	1,90	1,90	1,90	1,90	1,90	—
	0,75	2,37	2,37	2,37	2,37	2,37	2,37	2,37	2,37	—
	0,88	2,94	2,94	2,94	2,94	2,94	2,94	2,94	2,94	—
	1,00	3,52	3,52	3,52	3,52	3,52	3,52	3,52	3,52	—
$N_{R,k}$ [kN]	0,40	—	—	—	—	—	—	—	—	—
	0,50	1,96	1,96	1,96	1,96	1,96	1,96	1,96	1,96	—
	0,55	2,25	2,25	2,25	2,25	2,25	2,25	2,25	2,25	—
	0,60	2,57	2,57	2,57	2,57	2,57	2,57	2,57	2,57	—
	0,63	2,76	2,76	2,76	2,76	2,76	2,76	2,76	2,76	—
	0,75	3,49	3,49	3,49	3,49	3,49	3,49	3,49	3,49	—
	0,88	3,49	3,49	3,49	3,49	3,49	3,49	3,49	3,49	—
	1,00	3,49	3,49	3,49	3,49	3,49	3,49	3,49	3,49	—
$u$ [mm]	40	6,0	5,5	5,0	4,0	4,0	4,0	4,0	4,0	—
	50	8,0	7,5	7,0	6,0	6,0	6,0	6,0	6,0	—
	60	10,0	9,5	9,0	8,0	8,0	8,0	8,0	8,0	—
	70	12,5	11,5	11,0	9,5	9,5	9,5	9,5	9,5	—
	80	15,0	14,0	13,0	11,0	11,0	11,0	11,0	11,0	—
	100	15,0	14,0	13,0	11,0	11,0	11,0	11,0	11,0	—
	120	15,0	14,0	13,0	11,0	11,0	11,0	11,0	11,0	—
$N_{R,k,II}$ [kN]	4,65	6,40	7,74	8,36	8,36	8,36	8,36	8,36	—	

If component  $t_{N1}$  resp.  $t_{N2}$  is made of S320GD or S350GD the grey highlighted values may be increased by 8,3%.  
 If component  $t_{II}$  is made of S320GD the values  $N_{R,k,II}$  may be increased by 8,3%.

Self drilling screw	Annex 16
Hilti S-CDH 55 S 5,5 x L Hilti S-CDH 55 SS 5,5 x L with hexagon head and sealing washer $\varnothing 16$ mm	



Annex 6:  
ETA-13/0179, Annex 17

**Material:**  
 Fastener: stainless Steel (1.4301, 1.4401, 1.4571) - EN 10088  
 Washer: stainless Steel (1.4301) - EN 10088  
 Component I: S280GD, S320GD, S350GD - EN 10346  
 Component II: S235 - EN 10025-1  
 S280GD, S320GD - EN 10346

**Drilling capacity:**  $\Sigma t_i \leq 12,00$  mm

**Timber substructures:**  
no performance determined

$t_{N1}, t_{N2}, d, D$ [mm]	$t_i$ [mm]									
	3,00	4,00	5,00	6,00	8,00	9,00	10,0	11,0	$\geq 12,0$	
$V_{R,k}$ [kN]	0,40	0,99	0,99	0,99	0,99	0,99	0,99	0,99	0,99	—
	0,50	1,46	1,46	1,46	1,46	1,46	1,46	1,46	1,46	—
	0,55	1,62	1,62	1,62	1,62	1,62	1,62	1,62	1,62	—
	0,60	1,80	1,80	1,80	1,80	1,80	1,80	1,80	1,80	—
	0,63	1,90	1,90	1,90	1,90	1,90	1,90	1,90	1,90	—
	0,75	2,37	2,37	2,37	2,37	2,37	2,37	2,37	2,37	—
	0,88	2,94	2,94	2,94	2,94	2,94	2,94	2,94	2,94	—
	1,00	3,52	3,52	3,52	3,52	3,52	3,52	3,52	3,52	—
	$N_{R,k}$ [kN]	0,40	—	—	—	—	—	—	—	—
0,50		2,10	2,10	2,10	2,10	2,10	2,10	2,10	2,10	—
0,55		2,50	2,50	2,50	2,50	2,50	2,50	2,50	2,50	—
0,60		2,75	2,75	2,75	2,75	2,75	2,75	2,75	2,75	—
0,63		2,90	2,90	2,90	2,90	2,90	2,90	2,90	2,90	—
0,75		3,70	3,70	3,70	3,70	3,70	3,70	3,70	3,70	—
0,88		4,50	4,60	4,60	4,60	4,60	4,60	4,60	4,60	—
1,00		4,50	5,20	5,20	5,20	5,20	5,20	5,20	5,20	—
$u$ [mm]		40	6,0	5,5	5,0	4,0	4,0	4,0	4,0	4,0
	50	8,0	7,5	7,0	6,0	6,0	6,0	6,0	6,0	—
	60	10,0	9,5	9,0	8,0	8,0	8,0	8,0	8,0	—
	70	12,5	11,5	11,0	9,5	9,5	9,5	9,5	9,5	—
	80	15,0	14,0	13,0	11,0	11,0	11,0	11,0	11,0	—
	100	15,0	14,0	13,0	11,0	11,0	11,0	11,0	11,0	—
	120	15,0	14,0	13,0	11,0	11,0	11,0	11,0	11,0	—
	$\geq 140$	15,0	14,0	13,0	11,0	11,0	11,0	11,0	11,0	—
$N_{R,k,II}$ [kN]	4,65	6,40	7,74	8,36	8,36	8,36	8,36	8,36	—	

If component  $t_{N1}$  resp.  $t_{N2}$  is made of S320GD or S350GD the grey highlighted values may be increased by 8,3%. If both components  $t_{N1}$  and  $t_i$  are made of S320GD or S350GD the values  $N_{R,k}$  may be increased by 8,3%. If component  $t_i$  is made of S320GD the values  $N_{R,k,II}$  may be increased by 8,3%.

Self drilling screw	Annex 17
Hilti S-CDH 65 S 5,5 x L Hilti S-CDH 65 SS 5,5 x L Hilti S-CDH 75 S 5,5 x L Hilti S-CDH 75 SS 5,5 x L with hexagon head and sealing washer $\geq \varnothing 19$ mm	

Annex 7:  
ETA-13/0179, Annex 18

**Material:**  
 Fastener: stainless Steel (1.4301, 1.4401, 1.4571) - EN 10088  
 Washer: stainless Steel (1.4301) - EN 10088  
 Component I: S280GD, S320GD, S350GD - EN 10346  
 Component II: S235 - EN 10025-1  
 S280GD, S320GD - EN 10346

**Drilling capacity:**  $\Sigma t_i \leq 12,00$  mm

**Timber substructures:**  
no performance determined

$t_{N1}, t_{N2}, d, D$ [mm]	$t_i$ [mm]									
	3,00	4,00	5,00	6,00	8,00	9,00	10,0	11,0	$\geq 12,0$	
$V_{R,k}$ [kN]	0,40	0,99	0,99	0,99	0,99	0,99	0,99	0,99	0,99	—
	0,50	1,46	1,46	1,46	1,46	1,46	1,46	1,46	1,46	—
	0,55	1,62	1,62	1,62	1,62	1,62	1,62	1,62	1,62	—
	0,60	1,80	1,80	1,80	1,80	1,80	1,80	1,80	1,80	—
	0,63	1,90	1,90	1,90	1,90	1,90	1,90	1,90	1,90	—
	0,75	2,37	2,37	2,37	2,37	2,37	2,37	2,37	2,37	—
	0,88	2,94	2,94	2,94	2,94	2,94	2,94	2,94	2,94	—
	1,00	3,52	3,52	3,52	3,52	3,52	3,52	3,52	3,52	—
$N_{R,k}$ [kN]	0,40	—	—	—	—	—	—	—	—	—
	0,50	1,96	1,96	1,96	1,96	1,96	1,96	1,96	1,96	—
	0,55	2,25	2,25	2,25	2,25	2,25	2,25	2,25	2,25	—
	0,60	2,57	2,57	2,57	2,57	2,57	2,57	2,57	2,57	—
	0,63	2,76	2,76	2,76	2,76	2,76	2,76	2,76	2,76	—
	0,75	3,49	3,49	3,49	3,49	3,49	3,49	3,49	3,49	—
	0,88	3,49	3,49	3,49	3,49	3,49	3,49	3,49	3,49	—
	1,00	3,49	3,49	3,49	3,49	3,49	3,49	3,49	3,49	—
$u$ [mm]	40	6,0	5,5	5,0	4,0	4,0	4,0	4,0	4,0	—
	50	8,0	7,5	7,0	6,0	6,0	6,0	6,0	6,0	—
	60	10,0	9,5	9,0	8,0	8,0	8,0	8,0	8,0	—
	70	12,5	11,5	11,0	9,5	9,5	9,5	9,5	9,5	—
	80	15,0	14,0	13,0	11,0	11,0	11,0	11,0	11,0	—
	100	15,0	14,0	13,0	11,0	11,0	11,0	11,0	11,0	—
	120	15,0	14,0	13,0	11,0	11,0	11,0	11,0	11,0	—
$\geq 140$	15,0	14,0	13,0	11,0	11,0	11,0	11,0	11,0	—	
$N_{R,k,II}$ [kN]	4,65	6,40	7,74	8,36	8,36	8,36	8,36	8,36	—	

If component  $t_{N1}$  resp.  $t_{N2}$  is made of S320GD or S350GD the grey highlighted values may be increased by 8,3%.  
 If component  $t_i$  is made of S320GD the values  $N_{R,k,II}$  may be increased by 8,3%.

Self drilling screw	Annex 18
Hilti S-CD 55 S 5,5 x L Hilti S-CD 55 SS 5,5 x L with hexagon head and sealing washer $\varnothing 16$ mm	



Annex 8:  
ETA-13/0179, Annex 19

**Material:**  
 Fastener: stainless Steel (1.4301, 1.4401, 1.4571) - EN 10088  
 Washer: stainless Steel (1.4301) - EN 10088  
 Component I: S280GD, S320GD, S350GD - EN 10346  
 Component II: S235 - EN 10025-1  
 S280GD, S320GD - EN 10346

**Drilling capacity:**  $\Sigma t_i \leq 12,00$  mm

**Timber substructures:**  
no performance determined

$t_{N1}, t_{N2}, d, D$ [mm]	$t_{II}$ [mm]									
	3,00	4,00	5,00	6,00	8,00	9,00	10,0	11,0	$\geq 12,0$	
$V_{R,k}$ [kN]	0,40	0,99	0,99	0,99	0,99	0,99	0,99	0,99	0,99	—
	0,50	1,46	1,46	1,46	1,46	1,46	1,46	1,46	1,46	—
	0,55	1,62	1,62	1,62	1,62	1,62	1,62	1,62	1,62	—
	0,60	1,80	1,80	1,80	1,80	1,80	1,80	1,80	1,80	—
	0,63	1,90	1,90	1,90	1,90	1,90	1,90	1,90	1,90	—
	0,75	2,37	2,37	2,37	2,37	2,37	2,37	2,37	2,37	—
	0,88	2,94	2,94	2,94	2,94	2,94	2,94	2,94	2,94	—
	1,00	3,52	3,52	3,52	3,52	3,52	3,52	3,52	3,52	—
$N_{R,k}$ [kN]	0,40	—	—	—	—	—	—	—	—	—
	0,50	2,10	2,10	2,10	2,10	2,10	2,10	2,10	2,10	—
	0,55	2,50	2,50	2,50	2,50	2,50	2,50	2,50	2,50	—
	0,60	2,75	2,75	2,75	2,75	2,75	2,75	2,75	2,75	—
	0,63	2,90	2,90	2,90	2,90	2,90	2,90	2,90	2,90	—
	0,75	3,70	3,70	3,70	3,70	3,70	3,70	3,70	3,70	—
	0,88	4,50	4,60	4,60	4,60	4,60	4,60	4,60	4,60	—
	1,00	4,50	5,20	5,20	5,20	5,20	5,20	5,20	5,20	—
$u$ [mm]	40	6,0	5,5	5,0	4,0	4,0	4,0	4,0	4,0	—
	50	8,0	7,5	7,0	6,0	6,0	6,0	6,0	6,0	—
	60	10,0	9,5	9,0	8,0	8,0	8,0	8,0	8,0	—
	70	12,5	11,5	11,0	9,5	9,5	9,5	9,5	9,5	—
	80	15,0	14,0	13,0	11,0	11,0	11,0	11,0	11,0	—
	100	15,0	14,0	13,0	11,0	11,0	11,0	11,0	11,0	—
	120	15,0	14,0	13,0	11,0	11,0	11,0	11,0	11,0	—
$\geq 140$	15,0	14,0	13,0	11,0	11,0	11,0	11,0	11,0	—	
$N_{R,k,II}$ [kN]	4,65	6,40	7,74	8,36	8,36	8,36	8,36	8,36	—	

If component  $t_{N1}$  resp.  $t_{N2}$  is made of S320GD or S350GD the grey highlighted values may be increased by 8,3%. If both components  $t_{N1}$  and  $t_{II}$  are made of S320GD or S350GD the values  $N_{R,k}$  may be increased by 8,3%.  
 If component  $t_{II}$  is made of S320GD the values  $N_{R,k,II}$  may be increased by 8,3%.

Self drilling screw	Annex 19
Hilti S-CD 65 S 5,5 x L Hilti S-CD 65 SS 5,5 x L Hilti S-CD 75 S 5,5 x L Hilti S-CD 75 SS 5,5 x L with hexagon head and sealing washer $\geq \text{Ø}19$ mm	

Annex 9:  
ETA-13/0179, Annex 20

**Material:**  
 Fastener: stainless Steel (1.4301, 1.4401, 1.4571) - EN 10088  
 Washer: stainless Steel (1.4301) - EN 10088  
 Component I: S280GD, S320GD, S350GD - EN 10346  
 Component II: S235, S275, S355 - EN 10025-1  
 S280GD, S320GD, S350GD - EN 10346

**Drilling capacity:**  $\Sigma t_i \leq 15,00$  mm

**Timber substructures:**  
no performance determined

	$t_{N1}, t_{N2}, d, D$ [mm]	$t_{II}$ [mm]								
		4,00	5,00	6,00	7,00	8,00	$\geq 10,0$	—	—	—
$V_{R,k}$ [kN]	0,40	0,82	0,82	0,82	0,82	0,82	0,82	—	—	—
	0,50	0,93	0,93	0,93	0,93	0,93	0,93	—	—	—
	0,55	1,12	1,12	1,12	1,12	1,12	1,12	—	—	—
	0,60	1,31	1,31	1,31	1,31	1,31	1,31	—	—	—
	0,63	1,42	1,42	1,42	1,42	1,42	1,42	—	—	—
	0,75	1,88	1,88	1,88	1,88	1,88	1,88	—	—	—
	0,88	2,33	2,33	2,33	2,33	2,33	2,33	—	—	—
	1,00	2,74	2,74	2,74	2,74	2,74	2,74	—	—	—
$N_{R,k}$ [kN]	0,40	1,46	1,46	1,46	1,46	1,46	1,46	—	—	—
	0,50	1,89	1,89	1,89	1,89	1,89	1,89	—	—	—
	0,55	2,21	2,21	2,21	2,21	2,21	2,21	—	—	—
	0,60	2,53	2,53	2,53	2,53	2,53	2,53	—	—	—
	0,63	2,73	2,73	2,73	2,73	2,73	2,73	—	—	—
	0,75	3,50	3,50	3,50	3,50	3,50	3,50	—	—	—
	0,88	3,68	3,68	3,68	3,68	3,68	3,68	—	—	—
	1,00	3,84	3,84	3,84	3,84	3,84	3,84	—	—	—
$u$ [mm]	40	3,0	3,0	3,0	3,0	3,0	3,0	—	—	—
	50	4,5	4,5	4,5	4,5	4,5	4,5	—	—	—
	60	6,0	6,0	6,0	6,0	6,0	6,0	—	—	—
	70	7,4	7,4	7,4	7,4	7,4	7,4	—	—	—
	80	8,8	8,8	8,8	8,8	8,8	8,8	—	—	—
	90	10,1	10,1	10,1	10,1	10,1	10,1	—	—	—
	$\geq 100$	11,5	11,5	11,5	11,5	11,5	11,5	—	—	—
$N_{R,k,II}$ [kN]		3,92	4,92	5,91	6,22	6,52	6,52	—	—	—

No additional regulations.

Self drilling screw	Annex 20
Hilti S-CDH 55 GS 5,5 x L Hilti S-CDH 55 GSS 5,5 x L with hexagon head and sealing washer $\varnothing 16$ mm	

Annex 10:  
ETA-13/0179, Annex 21

	<b>Material:</b> Fastener: stainless Steel (1.4301, 1.4401, 1.4571) - EN 10088 Washer: stainless Steel (1.4301) - EN 10088 Component I: S280GD, S320GD, S350GD - EN 10346 Component II: S235, S275, S355 - EN 10025-1 S280GD, S320GD, S350GD - EN 10346																																																																																																																																																																																																																																																																													
	<b>Drilling capacity:</b> $\Sigma t_i \leq 15,00$ mm																																																																																																																																																																																																																																																																													
	<b>Timber substructures:</b> no performance determined																																																																																																																																																																																																																																																																													
<table border="1"> <thead> <tr> <th rowspan="2"><math>t_{N1}, t_{N2}, d, D</math> [mm]</th> <th colspan="7"><math>t_{II}</math> [mm]</th> <th rowspan="2">—</th> <th rowspan="2">—</th> <th rowspan="2">—</th> </tr> <tr> <th>4,00</th> <th>5,00</th> <th>6,00</th> <th>7,00</th> <th>8,00</th> <th><math>\geq 10,0</math></th> </tr> </thead> <tbody> <tr> <td rowspan="8"><math>V_{R,k}</math> [kN]</td> <td>0,40</td><td>0,82</td><td>0,82</td><td>0,82</td><td>0,82</td><td>0,82</td><td>0,82</td><td>—</td><td>—</td><td>—</td> </tr> <tr> <td>0,50</td><td>0,93</td><td>1,12</td><td>1,30</td><td>1,30</td><td>1,30</td><td>1,30</td><td>—</td><td>—</td><td>—</td> </tr> <tr> <td>0,55</td><td>1,12</td><td>1,28</td><td>1,44</td><td>1,44</td><td>1,44</td><td>1,44</td><td>—</td><td>—</td><td>—</td> </tr> <tr> <td>0,60</td><td>1,31</td><td>1,45</td><td>1,58</td><td>1,58</td><td>1,58</td><td>1,58</td><td>—</td><td>—</td><td>—</td> </tr> <tr> <td>0,63</td><td>1,42</td><td>1,54</td><td>1,66</td><td>1,66</td><td>1,66</td><td>1,66</td><td>—</td><td>—</td><td>—</td> </tr> <tr> <td>0,75</td><td>1,88</td><td>1,94</td><td>2,00</td><td>2,00</td><td>2,00</td><td>2,00</td><td>—</td><td>—</td><td>—</td> </tr> <tr> <td>0,88</td><td>2,33</td><td>2,57</td><td>2,81</td><td>2,81</td><td>2,81</td><td>2,81</td><td>—</td><td>—</td><td>—</td> </tr> <tr> <td>1,00</td><td>2,74</td><td>3,15</td><td>3,56</td><td>3,56</td><td>3,56</td><td>3,56</td><td>—</td><td>—</td><td>—</td> </tr> <tr> <td rowspan="8"><math>N_{R,k}</math> [kN]</td> <td>0,40</td><td>1,46</td><td>1,46</td><td>1,46</td><td>1,46</td><td>1,46</td><td>1,46</td><td>—</td><td>—</td><td>—</td> </tr> <tr> <td>0,50</td><td>1,89</td><td>1,89</td><td>1,89</td><td>1,89</td><td>1,89</td><td>1,89</td><td>—</td><td>—</td><td>—</td> </tr> <tr> <td>0,55</td><td>2,21</td><td>2,21</td><td>2,21</td><td>2,21</td><td>2,21</td><td>2,21</td><td>—</td><td>—</td><td>—</td> </tr> <tr> <td>0,60</td><td>2,53</td><td>2,53</td><td>2,53</td><td>2,53</td><td>2,53</td><td>2,53</td><td>—</td><td>—</td><td>—</td> </tr> <tr> <td>0,63</td><td>2,73</td><td>2,73</td><td>2,73</td><td>2,73</td><td>2,73</td><td>2,73</td><td>—</td><td>—</td><td>—</td> </tr> <tr> <td>0,75</td><td>3,50</td><td>3,50</td><td>3,50</td><td>3,50</td><td>3,50</td><td>3,50</td><td>—</td><td>—</td><td>—</td> </tr> <tr> <td>0,88</td><td>3,68</td><td>3,68</td><td>3,68</td><td>3,68</td><td>3,68</td><td>3,68</td><td>—</td><td>—</td><td>—</td> </tr> <tr> <td>1,00</td><td>3,84</td><td>3,84</td><td>3,84</td><td>3,84</td><td>3,84</td><td>3,84</td><td>—</td><td>—</td><td>—</td> </tr> <tr> <td rowspan="6"><math>u</math> [mm]</td> <td>40</td><td>3,0</td><td>3,0</td><td>3,0</td><td>3,0</td><td>3,0</td><td>3,0</td><td>—</td><td>—</td><td>—</td> </tr> <tr> <td>50</td><td>4,5</td><td>4,5</td><td>4,5</td><td>4,5</td><td>4,5</td><td>4,5</td><td>—</td><td>—</td><td>—</td> </tr> <tr> <td>60</td><td>6,0</td><td>6,0</td><td>6,0</td><td>6,0</td><td>6,0</td><td>6,0</td><td>—</td><td>—</td><td>—</td> </tr> <tr> <td>70</td><td>7,4</td><td>7,4</td><td>7,4</td><td>7,4</td><td>7,4</td><td>7,4</td><td>—</td><td>—</td><td>—</td> </tr> <tr> <td>80</td><td>8,8</td><td>8,8</td><td>8,8</td><td>8,8</td><td>8,8</td><td>8,8</td><td>—</td><td>—</td><td>—</td> </tr> <tr> <td>90</td><td>10,1</td><td>10,1</td><td>10,1</td><td>10,1</td><td>10,1</td><td>10,1</td><td>—</td><td>—</td><td>—</td> </tr> <tr> <td><math>\geq 100</math></td><td>11,5</td><td>11,5</td><td>11,5</td><td>11,5</td><td>11,5</td><td>11,5</td><td>—</td><td>—</td><td>—</td> </tr> <tr> <td><math>N_{R,k,II}</math> [kN]</td> <td>3,92</td><td>4,92</td><td>5,91</td><td>6,22</td><td>6,52</td><td>6,52</td><td>—</td><td>—</td><td>—</td> </tr> </tbody> </table>	$t_{N1}, t_{N2}, d, D$ [mm]	$t_{II}$ [mm]							—	—	—	4,00	5,00	6,00	7,00	8,00	$\geq 10,0$	$V_{R,k}$ [kN]	0,40	0,82	0,82	0,82	0,82	0,82	0,82	—	—	—	0,50	0,93	1,12	1,30	1,30	1,30	1,30	—	—	—	0,55	1,12	1,28	1,44	1,44	1,44	1,44	—	—	—	0,60	1,31	1,45	1,58	1,58	1,58	1,58	—	—	—	0,63	1,42	1,54	1,66	1,66	1,66	1,66	—	—	—	0,75	1,88	1,94	2,00	2,00	2,00	2,00	—	—	—	0,88	2,33	2,57	2,81	2,81	2,81	2,81	—	—	—	1,00	2,74	3,15	3,56	3,56	3,56	3,56	—	—	—	$N_{R,k}$ [kN]	0,40	1,46	1,46	1,46	1,46	1,46	1,46	—	—	—	0,50	1,89	1,89	1,89	1,89	1,89	1,89	—	—	—	0,55	2,21	2,21	2,21	2,21	2,21	2,21	—	—	—	0,60	2,53	2,53	2,53	2,53	2,53	2,53	—	—	—	0,63	2,73	2,73	2,73	2,73	2,73	2,73	—	—	—	0,75	3,50	3,50	3,50	3,50	3,50	3,50	—	—	—	0,88	3,68	3,68	3,68	3,68	3,68	3,68	—	—	—	1,00	3,84	3,84	3,84	3,84	3,84	3,84	—	—	—	$u$ [mm]	40	3,0	3,0	3,0	3,0	3,0	3,0	—	—	—	50	4,5	4,5	4,5	4,5	4,5	4,5	—	—	—	60	6,0	6,0	6,0	6,0	6,0	6,0	—	—	—	70	7,4	7,4	7,4	7,4	7,4	7,4	—	—	—	80	8,8	8,8	8,8	8,8	8,8	8,8	—	—	—	90	10,1	10,1	10,1	10,1	10,1	10,1	—	—	—	$\geq 100$	11,5	11,5	11,5	11,5	11,5	11,5	—	—	—	$N_{R,k,II}$ [kN]	3,92	4,92	5,91	6,22	6,52	6,52	—	—	—	No additional regulations.									
$t_{N1}, t_{N2}, d, D$ [mm]		$t_{II}$ [mm]										—	—	—																																																																																																																																																																																																																																																																
	4,00	5,00	6,00	7,00	8,00	$\geq 10,0$																																																																																																																																																																																																																																																																								
$V_{R,k}$ [kN]	0,40	0,82	0,82	0,82	0,82	0,82	0,82	—	—	—																																																																																																																																																																																																																																																																				
	0,50	0,93	1,12	1,30	1,30	1,30	1,30	—	—	—																																																																																																																																																																																																																																																																				
	0,55	1,12	1,28	1,44	1,44	1,44	1,44	—	—	—																																																																																																																																																																																																																																																																				
	0,60	1,31	1,45	1,58	1,58	1,58	1,58	—	—	—																																																																																																																																																																																																																																																																				
	0,63	1,42	1,54	1,66	1,66	1,66	1,66	—	—	—																																																																																																																																																																																																																																																																				
	0,75	1,88	1,94	2,00	2,00	2,00	2,00	—	—	—																																																																																																																																																																																																																																																																				
	0,88	2,33	2,57	2,81	2,81	2,81	2,81	—	—	—																																																																																																																																																																																																																																																																				
	1,00	2,74	3,15	3,56	3,56	3,56	3,56	—	—	—																																																																																																																																																																																																																																																																				
$N_{R,k}$ [kN]	0,40	1,46	1,46	1,46	1,46	1,46	1,46	—	—	—																																																																																																																																																																																																																																																																				
	0,50	1,89	1,89	1,89	1,89	1,89	1,89	—	—	—																																																																																																																																																																																																																																																																				
	0,55	2,21	2,21	2,21	2,21	2,21	2,21	—	—	—																																																																																																																																																																																																																																																																				
	0,60	2,53	2,53	2,53	2,53	2,53	2,53	—	—	—																																																																																																																																																																																																																																																																				
	0,63	2,73	2,73	2,73	2,73	2,73	2,73	—	—	—																																																																																																																																																																																																																																																																				
	0,75	3,50	3,50	3,50	3,50	3,50	3,50	—	—	—																																																																																																																																																																																																																																																																				
	0,88	3,68	3,68	3,68	3,68	3,68	3,68	—	—	—																																																																																																																																																																																																																																																																				
	1,00	3,84	3,84	3,84	3,84	3,84	3,84	—	—	—																																																																																																																																																																																																																																																																				
$u$ [mm]	40	3,0	3,0	3,0	3,0	3,0	3,0	—	—	—																																																																																																																																																																																																																																																																				
	50	4,5	4,5	4,5	4,5	4,5	4,5	—	—	—																																																																																																																																																																																																																																																																				
	60	6,0	6,0	6,0	6,0	6,0	6,0	—	—	—																																																																																																																																																																																																																																																																				
	70	7,4	7,4	7,4	7,4	7,4	7,4	—	—	—																																																																																																																																																																																																																																																																				
	80	8,8	8,8	8,8	8,8	8,8	8,8	—	—	—																																																																																																																																																																																																																																																																				
	90	10,1	10,1	10,1	10,1	10,1	10,1	—	—	—																																																																																																																																																																																																																																																																				
$\geq 100$	11,5	11,5	11,5	11,5	11,5	11,5	—	—	—																																																																																																																																																																																																																																																																					
$N_{R,k,II}$ [kN]	3,92	4,92	5,91	6,22	6,52	6,52	—	—	—																																																																																																																																																																																																																																																																					
Self drilling screw										Annex 21																																																																																																																																																																																																																																																																				
Hilti S-CDH 65 GS 5,5 x L Hilti S-CDH 65 GSS 5,5 x L with hexagon head and sealing washer $\varnothing 19$ mm																																																																																																																																																																																																																																																																														

Annex 11:  
ETA-13/0179, Annex 22

	<p><b>Material:</b>  <b>Fastener:</b> stainless Steel (1.4301, 1.4401, 1.4571) - EN 10088  <b>Washer:</b> stainless Steel (1.4301) - EN 10088  <b>Component I:</b> S280GD, S320GD, S350GD - EN 10346  <b>Component II:</b> S235, S275, S355 - EN 10025-1                  S280GD, S320GD, S350GD - EN 10346</p>																																																																																																																																																																																																																																																																																																
<p><b>Drilling capacity:</b> <math>\Sigma t_i \leq 15,00</math> mm</p>																																																																																																																																																																																																																																																																																																	
<p><b>Timber substructures:</b> no performance determined</p>																																																																																																																																																																																																																																																																																																	
<table border="1"> <thead> <tr> <th rowspan="2"><math>t_{N1}, t_{N2}, d, D</math> [mm]</th> <th colspan="10"><math>t_{II}</math> [mm]</th> </tr> <tr> <th>4,00</th> <th>5,00</th> <th>6,00</th> <th>7,00</th> <th>8,00</th> <th><math>\geq 10,0</math></th> <th>—</th> <th>—</th> <th>—</th> <th>—</th> </tr> </thead> <tbody> <tr> <td rowspan="8"><math>V_{R,k}</math> [kN]</td> <td>0,40</td><td>0,82</td><td>0,82</td><td>0,82</td><td>0,82</td><td>0,82</td><td>0,82</td><td>—</td><td>—</td><td>—</td><td>—</td> </tr> <tr> <td>0,50</td><td>0,93</td><td>1,12</td><td>1,30</td><td>1,30</td><td>1,30</td><td>1,30</td><td>—</td><td>—</td><td>—</td><td>—</td> </tr> <tr> <td>0,55</td><td>1,12</td><td>1,28</td><td>1,44</td><td>1,44</td><td>1,44</td><td>1,44</td><td>—</td><td>—</td><td>—</td><td>—</td> </tr> <tr> <td>0,60</td><td>1,31</td><td>1,45</td><td>1,58</td><td>1,58</td><td>1,58</td><td>1,58</td><td>—</td><td>—</td><td>—</td><td>—</td> </tr> <tr> <td>0,63</td><td>1,42</td><td>1,54</td><td>1,66</td><td>1,66</td><td>1,66</td><td>1,66</td><td>—</td><td>—</td><td>—</td><td>—</td> </tr> <tr> <td>0,75</td><td>1,88</td><td>1,94</td><td>2,00</td><td>2,00</td><td>2,00</td><td>2,00</td><td>—</td><td>—</td><td>—</td><td>—</td> </tr> <tr> <td>0,88</td><td>2,33</td><td>2,57</td><td>2,81</td><td>2,81</td><td>2,81</td><td>2,81</td><td>—</td><td>—</td><td>—</td><td>—</td> </tr> <tr> <td>1,00</td><td>2,74</td><td>3,15</td><td>3,56</td><td>3,56</td><td>3,56</td><td>3,56</td><td>—</td><td>—</td><td>—</td><td>—</td> </tr> <tr> <td rowspan="8"><math>N_{R,k}</math> [kN]</td> <td>0,40</td><td>1,65</td><td>1,65</td><td>1,65</td><td>1,65</td><td>1,65</td><td>1,65</td><td>—</td><td>—</td><td>—</td><td>—</td> </tr> <tr> <td>0,50</td><td>1,77</td><td>1,77</td><td>1,77</td><td>1,77</td><td>1,77</td><td>1,77</td><td>—</td><td>—</td><td>—</td><td>—</td> </tr> <tr> <td>0,55</td><td>2,26</td><td>2,26</td><td>2,26</td><td>2,26</td><td>2,26</td><td>2,26</td><td>—</td><td>—</td><td>—</td><td>—</td> </tr> <tr> <td>0,60</td><td>2,74</td><td>2,74</td><td>2,74</td><td>2,74</td><td>2,74</td><td>2,74</td><td>—</td><td>—</td><td>—</td><td>—</td> </tr> <tr> <td>0,63</td><td>3,03</td><td>3,03</td><td>3,03</td><td>3,03</td><td>3,03</td><td>3,03</td><td>—</td><td>—</td><td>—</td><td>—</td> </tr> <tr> <td>0,75</td><td>3,92</td><td>4,20</td><td>4,20</td><td>4,20</td><td>4,20</td><td>4,20</td><td>—</td><td>—</td><td>—</td><td>—</td> </tr> <tr> <td>0,88</td><td>3,92</td><td>4,32</td><td>4,32</td><td>4,32</td><td>4,32</td><td>4,32</td><td>—</td><td>—</td><td>—</td><td>—</td> </tr> <tr> <td>1,00</td><td>3,92</td><td>4,44</td><td>4,44</td><td>4,44</td><td>4,44</td><td>4,44</td><td>—</td><td>—</td><td>—</td><td>—</td> </tr> <tr> <td rowspan="6"><math>u</math> [mm]</td> <td>40</td><td>3,0</td><td>3,0</td><td>3,0</td><td>3,0</td><td>3,0</td><td>3,0</td><td>—</td><td>—</td><td>—</td><td>—</td> </tr> <tr> <td>50</td><td>4,5</td><td>4,5</td><td>4,5</td><td>4,5</td><td>4,5</td><td>4,5</td><td>—</td><td>—</td><td>—</td><td>—</td> </tr> <tr> <td>60</td><td>6,0</td><td>6,0</td><td>6,0</td><td>6,0</td><td>6,0</td><td>6,0</td><td>—</td><td>—</td><td>—</td><td>—</td> </tr> <tr> <td>70</td><td>7,4</td><td>7,4</td><td>7,4</td><td>7,4</td><td>7,4</td><td>7,4</td><td>—</td><td>—</td><td>—</td><td>—</td> </tr> <tr> <td>80</td><td>8,8</td><td>8,8</td><td>8,8</td><td>8,8</td><td>8,8</td><td>8,8</td><td>—</td><td>—</td><td>—</td><td>—</td> </tr> <tr> <td>90</td><td>10,1</td><td>10,1</td><td>10,1</td><td>10,1</td><td>10,1</td><td>10,1</td><td>—</td><td>—</td><td>—</td><td>—</td> </tr> <tr> <td><math>\geq 100</math></td><td>11,5</td><td>11,5</td><td>11,5</td><td>11,5</td><td>11,5</td><td>11,5</td><td>—</td><td>—</td><td>—</td><td>—</td> </tr> <tr> <td><math>N_{R,k,II}</math> [kN]</td> <td>3,92</td><td>4,92</td><td>5,91</td><td>6,22</td><td>6,52</td><td>6,52</td><td>—</td><td>—</td><td>—</td><td>—</td> </tr> </tbody> </table>	$t_{N1}, t_{N2}, d, D$ [mm]	$t_{II}$ [mm]										4,00	5,00	6,00	7,00	8,00	$\geq 10,0$	—	—	—	—	$V_{R,k}$ [kN]	0,40	0,82	0,82	0,82	0,82	0,82	0,82	—	—	—	—	0,50	0,93	1,12	1,30	1,30	1,30	1,30	—	—	—	—	0,55	1,12	1,28	1,44	1,44	1,44	1,44	—	—	—	—	0,60	1,31	1,45	1,58	1,58	1,58	1,58	—	—	—	—	0,63	1,42	1,54	1,66	1,66	1,66	1,66	—	—	—	—	0,75	1,88	1,94	2,00	2,00	2,00	2,00	—	—	—	—	0,88	2,33	2,57	2,81	2,81	2,81	2,81	—	—	—	—	1,00	2,74	3,15	3,56	3,56	3,56	3,56	—	—	—	—	$N_{R,k}$ [kN]	0,40	1,65	1,65	1,65	1,65	1,65	1,65	—	—	—	—	0,50	1,77	1,77	1,77	1,77	1,77	1,77	—	—	—	—	0,55	2,26	2,26	2,26	2,26	2,26	2,26	—	—	—	—	0,60	2,74	2,74	2,74	2,74	2,74	2,74	—	—	—	—	0,63	3,03	3,03	3,03	3,03	3,03	3,03	—	—	—	—	0,75	3,92	4,20	4,20	4,20	4,20	4,20	—	—	—	—	0,88	3,92	4,32	4,32	4,32	4,32	4,32	—	—	—	—	1,00	3,92	4,44	4,44	4,44	4,44	4,44	—	—	—	—	$u$ [mm]	40	3,0	3,0	3,0	3,0	3,0	3,0	—	—	—	—	50	4,5	4,5	4,5	4,5	4,5	4,5	—	—	—	—	60	6,0	6,0	6,0	6,0	6,0	6,0	—	—	—	—	70	7,4	7,4	7,4	7,4	7,4	7,4	—	—	—	—	80	8,8	8,8	8,8	8,8	8,8	8,8	—	—	—	—	90	10,1	10,1	10,1	10,1	10,1	10,1	—	—	—	—	$\geq 100$	11,5	11,5	11,5	11,5	11,5	11,5	—	—	—	—	$N_{R,k,II}$ [kN]	3,92	4,92	5,91	6,22	6,52	6,52	—	—	—	—	<p>No additional regulations.</p>
$t_{N1}, t_{N2}, d, D$ [mm]		$t_{II}$ [mm]																																																																																																																																																																																																																																																																																															
	4,00	5,00	6,00	7,00	8,00	$\geq 10,0$	—	—	—	—																																																																																																																																																																																																																																																																																							
$V_{R,k}$ [kN]	0,40	0,82	0,82	0,82	0,82	0,82	0,82	—	—	—	—																																																																																																																																																																																																																																																																																						
	0,50	0,93	1,12	1,30	1,30	1,30	1,30	—	—	—	—																																																																																																																																																																																																																																																																																						
	0,55	1,12	1,28	1,44	1,44	1,44	1,44	—	—	—	—																																																																																																																																																																																																																																																																																						
	0,60	1,31	1,45	1,58	1,58	1,58	1,58	—	—	—	—																																																																																																																																																																																																																																																																																						
	0,63	1,42	1,54	1,66	1,66	1,66	1,66	—	—	—	—																																																																																																																																																																																																																																																																																						
	0,75	1,88	1,94	2,00	2,00	2,00	2,00	—	—	—	—																																																																																																																																																																																																																																																																																						
	0,88	2,33	2,57	2,81	2,81	2,81	2,81	—	—	—	—																																																																																																																																																																																																																																																																																						
	1,00	2,74	3,15	3,56	3,56	3,56	3,56	—	—	—	—																																																																																																																																																																																																																																																																																						
$N_{R,k}$ [kN]	0,40	1,65	1,65	1,65	1,65	1,65	1,65	—	—	—	—																																																																																																																																																																																																																																																																																						
	0,50	1,77	1,77	1,77	1,77	1,77	1,77	—	—	—	—																																																																																																																																																																																																																																																																																						
	0,55	2,26	2,26	2,26	2,26	2,26	2,26	—	—	—	—																																																																																																																																																																																																																																																																																						
	0,60	2,74	2,74	2,74	2,74	2,74	2,74	—	—	—	—																																																																																																																																																																																																																																																																																						
	0,63	3,03	3,03	3,03	3,03	3,03	3,03	—	—	—	—																																																																																																																																																																																																																																																																																						
	0,75	3,92	4,20	4,20	4,20	4,20	4,20	—	—	—	—																																																																																																																																																																																																																																																																																						
	0,88	3,92	4,32	4,32	4,32	4,32	4,32	—	—	—	—																																																																																																																																																																																																																																																																																						
	1,00	3,92	4,44	4,44	4,44	4,44	4,44	—	—	—	—																																																																																																																																																																																																																																																																																						
$u$ [mm]	40	3,0	3,0	3,0	3,0	3,0	3,0	—	—	—	—																																																																																																																																																																																																																																																																																						
	50	4,5	4,5	4,5	4,5	4,5	4,5	—	—	—	—																																																																																																																																																																																																																																																																																						
	60	6,0	6,0	6,0	6,0	6,0	6,0	—	—	—	—																																																																																																																																																																																																																																																																																						
	70	7,4	7,4	7,4	7,4	7,4	7,4	—	—	—	—																																																																																																																																																																																																																																																																																						
	80	8,8	8,8	8,8	8,8	8,8	8,8	—	—	—	—																																																																																																																																																																																																																																																																																						
	90	10,1	10,1	10,1	10,1	10,1	10,1	—	—	—	—																																																																																																																																																																																																																																																																																						
$\geq 100$	11,5	11,5	11,5	11,5	11,5	11,5	—	—	—	—																																																																																																																																																																																																																																																																																							
$N_{R,k,II}$ [kN]	3,92	4,92	5,91	6,22	6,52	6,52	—	—	—	—																																																																																																																																																																																																																																																																																							
<p style="text-align: center;">Self drilling screw</p> <hr/> <p style="text-align: center;">Hilti S-CDH 75 GS 5,5 x L                  Hilti S-CDH 75 GSS 5,5 x L                  with hexagon head and sealing washer <math>\varnothing 22</math> mm</p> <div style="float: right; text-align: right;">Annex 22</div>																																																																																																																																																																																																																																																																																																	

Annex 12:  
ETA-13/0179, Annex 23

**Material:**  
 Fastener: stainless Steel (1.4301, 1.4401, 1.4571) - EN 10088  
 Washer: stainless Steel (1.4301) - EN 10088  
 Component I: S280GD, S320GD, S350GD - EN 10346  
 Component II: S235, S275, S355 - EN 10025-1  
 S280GD, S320GD, S350GD - EN 10346

**Drilling capacity:**  $\Sigma t_i \leq 15,00$  mm

**Timber substructures:**  
no performance determined

$t_{N1}, t_{N2}, d, D$ [mm]	$t_{II}$ [mm]						—	—	—	
	4,00	5,00	6,00	7,00	8,00	$\geq 10,0$				
$V_{R,k}$ [kN]	0,40	0,82	0,82	0,82	0,82	0,82	0,82	—	—	—
	0,50	0,93	0,93	0,93	0,93	0,93	0,93	—	—	—
	0,55	1,12	1,12	1,12	1,12	1,12	1,12	—	—	—
	0,60	1,31	1,31	1,31	1,31	1,31	1,31	—	—	—
	0,63	1,42	1,42	1,42	1,42	1,42	1,42	—	—	—
	0,75	1,88	1,88	1,88	1,88	1,88	1,88	—	—	—
	0,88	2,33	2,33	2,33	2,33	2,33	2,33	—	—	—
	1,00	2,74	2,74	2,74	2,74	2,74	2,74	—	—	—
$N_{R,k}$ [kN]	0,40	1,46	1,46	1,46	1,46	1,46	1,46	—	—	—
	0,50	1,89	1,89	1,89	1,89	1,89	1,89	—	—	—
	0,55	2,21	2,21	2,21	2,21	2,21	2,21	—	—	—
	0,60	2,53	2,53	2,53	2,53	2,53	2,53	—	—	—
	0,63	2,73	2,73	2,73	2,73	2,73	2,73	—	—	—
	0,75	3,50	3,50	3,50	3,50	3,50	3,50	—	—	—
	0,88	3,68	3,68	3,68	3,68	3,68	3,68	—	—	—
	1,00	3,84	3,84	3,84	3,84	3,84	3,84	—	—	—
$u$ [mm]	40	3,0	3,0	3,0	3,0	3,0	3,0	—	—	—
	50	4,5	4,5	4,5	4,5	4,5	4,5	—	—	—
	60	6,0	6,0	6,0	6,0	6,0	6,0	—	—	—
	70	7,4	7,4	7,4	7,4	7,4	7,4	—	—	—
	80	8,8	8,8	8,8	8,8	8,8	8,8	—	—	—
	90	10,1	10,1	10,1	10,1	10,1	10,1	—	—	—
$\geq 100$	11,5	11,5	11,5	11,5	11,5	11,5	—	—	—	
$N_{R,k,II}$ [kN]	3,92	4,92	5,91	6,22	6,52	6,52	—	—	—	

No additional regulations.

Self drilling screw	Annex 23
Hilti S-CD 55 GS 5,5 x L Hilti S-CD 55 GSS 5,5 x L with hexagon head and sealing washer Ø16 mm	

Annex 13:  
ETA-13/0179, Annex 24

	<p><b>Material:</b></p> <p>Fastener: stainless Steel (1.4301, 1.4401, 1.4571) - EN 10088</p> <p>Washer: stainless Steel (1.4301) - EN 10088</p> <p>Component I: S280GD, S320GD, S350GD - EN 10346</p> <p>Component II: S235, S275, S355 - EN 10025-1 S280GD, S320GD, S350GD - EN 10346</p>																																																																																																																																																																																																																																																																																																			
	<p><b>Drilling capacity:</b> <math>\Sigma t_i \leq 15,00</math> mm</p>																																																																																																																																																																																																																																																																																																			
<p><b>Timber substructures:</b> no performance determined</p>																																																																																																																																																																																																																																																																																																				
<table border="1"> <thead> <tr> <th rowspan="2"><math>t_{N1}, t_{N2}, d, D</math> [mm]</th> <th colspan="10"><math>t_{II}</math> [mm]</th> </tr> <tr> <th>4,00</th> <th>5,00</th> <th>6,00</th> <th>7,00</th> <th>8,00</th> <th><math>\geq 10,0</math></th> <th>—</th> <th>—</th> <th>—</th> <th>—</th> </tr> </thead> <tbody> <tr> <td rowspan="8"><math>V_{R,k}</math> [kN]</td> <td>0,40</td><td>0,82</td><td>0,82</td><td>0,82</td><td>0,82</td><td>0,82</td><td>0,82</td><td>—</td><td>—</td><td>—</td><td>—</td> </tr> <tr> <td>0,50</td><td>0,93</td><td>1,12</td><td>1,30</td><td>1,30</td><td>1,30</td><td>1,30</td><td>—</td><td>—</td><td>—</td><td>—</td> </tr> <tr> <td>0,55</td><td>1,12</td><td>1,28</td><td>1,44</td><td>1,44</td><td>1,44</td><td>1,44</td><td>—</td><td>—</td><td>—</td><td>—</td> </tr> <tr> <td>0,60</td><td>1,31</td><td>1,45</td><td>1,58</td><td>1,58</td><td>1,58</td><td>1,58</td><td>—</td><td>—</td><td>—</td><td>—</td> </tr> <tr> <td>0,63</td><td>1,42</td><td>1,54</td><td>1,66</td><td>1,66</td><td>1,66</td><td>1,66</td><td>—</td><td>—</td><td>—</td><td>—</td> </tr> <tr> <td>0,75</td><td>1,88</td><td>1,94</td><td>2,00</td><td>2,00</td><td>2,00</td><td>2,00</td><td>—</td><td>—</td><td>—</td><td>—</td> </tr> <tr> <td>0,88</td><td>2,33</td><td>2,57</td><td>2,81</td><td>2,81</td><td>2,81</td><td>2,81</td><td>—</td><td>—</td><td>—</td><td>—</td> </tr> <tr> <td>1,00</td><td>2,74</td><td>3,15</td><td>3,56</td><td>3,56</td><td>3,56</td><td>3,56</td><td>—</td><td>—</td><td>—</td><td>—</td> </tr> <tr> <td rowspan="8"><math>N_{R,k}</math> [kN]</td> <td>0,40</td><td>1,46</td><td>1,46</td><td>1,46</td><td>1,46</td><td>1,46</td><td>1,46</td><td>—</td><td>—</td><td>—</td><td>—</td> </tr> <tr> <td>0,50</td><td>1,89</td><td>1,89</td><td>1,89</td><td>1,89</td><td>1,89</td><td>1,89</td><td>—</td><td>—</td><td>—</td><td>—</td> </tr> <tr> <td>0,55</td><td>2,21</td><td>2,21</td><td>2,21</td><td>2,21</td><td>2,21</td><td>2,21</td><td>—</td><td>—</td><td>—</td><td>—</td> </tr> <tr> <td>0,60</td><td>2,53</td><td>2,53</td><td>2,53</td><td>2,53</td><td>2,53</td><td>2,53</td><td>—</td><td>—</td><td>—</td><td>—</td> </tr> <tr> <td>0,63</td><td>2,73</td><td>2,73</td><td>2,73</td><td>2,73</td><td>2,73</td><td>2,73</td><td>—</td><td>—</td><td>—</td><td>—</td> </tr> <tr> <td>0,75</td><td>3,50</td><td>3,50</td><td>3,50</td><td>3,50</td><td>3,50</td><td>3,50</td><td>—</td><td>—</td><td>—</td><td>—</td> </tr> <tr> <td>0,88</td><td>3,68</td><td>3,68</td><td>3,68</td><td>3,68</td><td>3,68</td><td>3,68</td><td>—</td><td>—</td><td>—</td><td>—</td> </tr> <tr> <td>1,00</td><td>3,84</td><td>3,84</td><td>3,84</td><td>3,84</td><td>3,84</td><td>3,84</td><td>—</td><td>—</td><td>—</td><td>—</td> </tr> <tr> <td rowspan="6"><math>u</math> [mm]</td> <td>40</td><td>3,0</td><td>3,0</td><td>3,0</td><td>3,0</td><td>3,0</td><td>3,0</td><td>—</td><td>—</td><td>—</td><td>—</td> </tr> <tr> <td>50</td><td>4,5</td><td>4,5</td><td>4,5</td><td>4,5</td><td>4,5</td><td>4,5</td><td>—</td><td>—</td><td>—</td><td>—</td> </tr> <tr> <td>60</td><td>6,0</td><td>6,0</td><td>6,0</td><td>6,0</td><td>6,0</td><td>6,0</td><td>—</td><td>—</td><td>—</td><td>—</td> </tr> <tr> <td>70</td><td>7,4</td><td>7,4</td><td>7,4</td><td>7,4</td><td>7,4</td><td>7,4</td><td>—</td><td>—</td><td>—</td><td>—</td> </tr> <tr> <td>80</td><td>8,8</td><td>8,8</td><td>8,8</td><td>8,8</td><td>8,8</td><td>8,8</td><td>—</td><td>—</td><td>—</td><td>—</td> </tr> <tr> <td>90</td><td>10,1</td><td>10,1</td><td>10,1</td><td>10,1</td><td>10,1</td><td>10,1</td><td>—</td><td>—</td><td>—</td><td>—</td> </tr> <tr> <td><math>\geq 100</math></td><td>11,5</td><td>11,5</td><td>11,5</td><td>11,5</td><td>11,5</td><td>11,5</td><td>—</td><td>—</td><td>—</td><td>—</td> </tr> <tr> <td><math>N_{R,k,II}</math> [kN]</td> <td>3,92</td><td>4,92</td><td>5,91</td><td>6,22</td><td>6,52</td><td>6,52</td><td>—</td><td>—</td><td>—</td><td>—</td> </tr> </tbody> </table>	$t_{N1}, t_{N2}, d, D$ [mm]	$t_{II}$ [mm]										4,00	5,00	6,00	7,00	8,00	$\geq 10,0$	—	—	—	—	$V_{R,k}$ [kN]	0,40	0,82	0,82	0,82	0,82	0,82	0,82	—	—	—	—	0,50	0,93	1,12	1,30	1,30	1,30	1,30	—	—	—	—	0,55	1,12	1,28	1,44	1,44	1,44	1,44	—	—	—	—	0,60	1,31	1,45	1,58	1,58	1,58	1,58	—	—	—	—	0,63	1,42	1,54	1,66	1,66	1,66	1,66	—	—	—	—	0,75	1,88	1,94	2,00	2,00	2,00	2,00	—	—	—	—	0,88	2,33	2,57	2,81	2,81	2,81	2,81	—	—	—	—	1,00	2,74	3,15	3,56	3,56	3,56	3,56	—	—	—	—	$N_{R,k}$ [kN]	0,40	1,46	1,46	1,46	1,46	1,46	1,46	—	—	—	—	0,50	1,89	1,89	1,89	1,89	1,89	1,89	—	—	—	—	0,55	2,21	2,21	2,21	2,21	2,21	2,21	—	—	—	—	0,60	2,53	2,53	2,53	2,53	2,53	2,53	—	—	—	—	0,63	2,73	2,73	2,73	2,73	2,73	2,73	—	—	—	—	0,75	3,50	3,50	3,50	3,50	3,50	3,50	—	—	—	—	0,88	3,68	3,68	3,68	3,68	3,68	3,68	—	—	—	—	1,00	3,84	3,84	3,84	3,84	3,84	3,84	—	—	—	—	$u$ [mm]	40	3,0	3,0	3,0	3,0	3,0	3,0	—	—	—	—	50	4,5	4,5	4,5	4,5	4,5	4,5	—	—	—	—	60	6,0	6,0	6,0	6,0	6,0	6,0	—	—	—	—	70	7,4	7,4	7,4	7,4	7,4	7,4	—	—	—	—	80	8,8	8,8	8,8	8,8	8,8	8,8	—	—	—	—	90	10,1	10,1	10,1	10,1	10,1	10,1	—	—	—	—	$\geq 100$	11,5	11,5	11,5	11,5	11,5	11,5	—	—	—	—	$N_{R,k,II}$ [kN]	3,92	4,92	5,91	6,22	6,52	6,52	—	—	—	—	No additional regulations.			
$t_{N1}, t_{N2}, d, D$ [mm]		$t_{II}$ [mm]																																																																																																																																																																																																																																																																																																		
	4,00	5,00	6,00	7,00	8,00	$\geq 10,0$	—	—	—	—																																																																																																																																																																																																																																																																																										
$V_{R,k}$ [kN]	0,40	0,82	0,82	0,82	0,82	0,82	0,82	—	—	—	—																																																																																																																																																																																																																																																																																									
	0,50	0,93	1,12	1,30	1,30	1,30	1,30	—	—	—	—																																																																																																																																																																																																																																																																																									
	0,55	1,12	1,28	1,44	1,44	1,44	1,44	—	—	—	—																																																																																																																																																																																																																																																																																									
	0,60	1,31	1,45	1,58	1,58	1,58	1,58	—	—	—	—																																																																																																																																																																																																																																																																																									
	0,63	1,42	1,54	1,66	1,66	1,66	1,66	—	—	—	—																																																																																																																																																																																																																																																																																									
	0,75	1,88	1,94	2,00	2,00	2,00	2,00	—	—	—	—																																																																																																																																																																																																																																																																																									
	0,88	2,33	2,57	2,81	2,81	2,81	2,81	—	—	—	—																																																																																																																																																																																																																																																																																									
	1,00	2,74	3,15	3,56	3,56	3,56	3,56	—	—	—	—																																																																																																																																																																																																																																																																																									
$N_{R,k}$ [kN]	0,40	1,46	1,46	1,46	1,46	1,46	1,46	—	—	—	—																																																																																																																																																																																																																																																																																									
	0,50	1,89	1,89	1,89	1,89	1,89	1,89	—	—	—	—																																																																																																																																																																																																																																																																																									
	0,55	2,21	2,21	2,21	2,21	2,21	2,21	—	—	—	—																																																																																																																																																																																																																																																																																									
	0,60	2,53	2,53	2,53	2,53	2,53	2,53	—	—	—	—																																																																																																																																																																																																																																																																																									
	0,63	2,73	2,73	2,73	2,73	2,73	2,73	—	—	—	—																																																																																																																																																																																																																																																																																									
	0,75	3,50	3,50	3,50	3,50	3,50	3,50	—	—	—	—																																																																																																																																																																																																																																																																																									
	0,88	3,68	3,68	3,68	3,68	3,68	3,68	—	—	—	—																																																																																																																																																																																																																																																																																									
	1,00	3,84	3,84	3,84	3,84	3,84	3,84	—	—	—	—																																																																																																																																																																																																																																																																																									
$u$ [mm]	40	3,0	3,0	3,0	3,0	3,0	3,0	—	—	—	—																																																																																																																																																																																																																																																																																									
	50	4,5	4,5	4,5	4,5	4,5	4,5	—	—	—	—																																																																																																																																																																																																																																																																																									
	60	6,0	6,0	6,0	6,0	6,0	6,0	—	—	—	—																																																																																																																																																																																																																																																																																									
	70	7,4	7,4	7,4	7,4	7,4	7,4	—	—	—	—																																																																																																																																																																																																																																																																																									
	80	8,8	8,8	8,8	8,8	8,8	8,8	—	—	—	—																																																																																																																																																																																																																																																																																									
	90	10,1	10,1	10,1	10,1	10,1	10,1	—	—	—	—																																																																																																																																																																																																																																																																																									
$\geq 100$	11,5	11,5	11,5	11,5	11,5	11,5	—	—	—	—																																																																																																																																																																																																																																																																																										
$N_{R,k,II}$ [kN]	3,92	4,92	5,91	6,22	6,52	6,52	—	—	—	—																																																																																																																																																																																																																																																																																										
Self drilling screw				Annex 24																																																																																																																																																																																																																																																																																																
Hilti S-CD 65 GS 5,5 x L Hilti S-CD 65 GSS 5,5 x L with hexagon head and sealing washer $\varnothing 19$ mm																																																																																																																																																																																																																																																																																																				



Annex 14:  
ETA-13/0179, Annex 25

	<p><b>Material:</b>  <b>Fastener:</b> stainless Steel (1.4301, 1.4401, 1.4571) - EN 10088  <b>Washer:</b> stainless Steel (1.4301) - EN 10088  <b>Component I:</b> S280GD, S320GD, S350GD - EN 10346  <b>Component II:</b> S235, S275, S355 - EN 10025-1                  S280GD, S320GD, S350GD - EN 10346</p>																																																																																																																																																																																																																																																																																																
<p><b>Drilling capacity:</b> <math>\Sigma t_i \leq 15,00</math> mm</p>																																																																																																																																																																																																																																																																																																	
<p><b>Timber substructures:</b> no performance determined</p>																																																																																																																																																																																																																																																																																																	
<table border="1"> <thead> <tr> <th rowspan="2"><math>t_{N1}, t_{N2}, d, D</math> [mm]</th> <th colspan="10"><math>t_{II}</math> [mm]</th> </tr> <tr> <th>4,00</th> <th>5,00</th> <th>6,00</th> <th>7,00</th> <th>8,00</th> <th><math>\geq 10,0</math></th> <th>—</th> <th>—</th> <th>—</th> <th>—</th> </tr> </thead> <tbody> <tr> <td rowspan="8"><math>V_{R,k}</math> [kN]</td> <td>0,40</td><td>0,82</td><td>0,82</td><td>0,82</td><td>0,82</td><td>0,82</td><td>0,82</td><td>—</td><td>—</td><td>—</td><td>—</td> </tr> <tr> <td>0,50</td><td>0,93</td><td>1,12</td><td>1,30</td><td>1,30</td><td>1,30</td><td>1,30</td><td>—</td><td>—</td><td>—</td><td>—</td> </tr> <tr> <td>0,55</td><td>1,12</td><td>1,28</td><td>1,44</td><td>1,44</td><td>1,44</td><td>1,44</td><td>—</td><td>—</td><td>—</td><td>—</td> </tr> <tr> <td>0,60</td><td>1,31</td><td>1,45</td><td>1,58</td><td>1,58</td><td>1,58</td><td>1,58</td><td>—</td><td>—</td><td>—</td><td>—</td> </tr> <tr> <td>0,63</td><td>1,42</td><td>1,54</td><td>1,66</td><td>1,66</td><td>1,66</td><td>1,66</td><td>—</td><td>—</td><td>—</td><td>—</td> </tr> <tr> <td>0,75</td><td>1,88</td><td>1,94</td><td>2,00</td><td>2,00</td><td>2,00</td><td>2,00</td><td>—</td><td>—</td><td>—</td><td>—</td> </tr> <tr> <td>0,88</td><td>2,33</td><td>2,57</td><td>2,81</td><td>2,81</td><td>2,81</td><td>2,81</td><td>—</td><td>—</td><td>—</td><td>—</td> </tr> <tr> <td>1,00</td><td>2,74</td><td>3,15</td><td>3,56</td><td>3,56</td><td>3,56</td><td>3,56</td><td>—</td><td>—</td><td>—</td><td>—</td> </tr> <tr> <td rowspan="8"><math>N_{R,k}</math> [kN]</td> <td>0,40</td><td>1,65</td><td>1,65</td><td>1,65</td><td>1,65</td><td>1,65</td><td>1,65</td><td>—</td><td>—</td><td>—</td><td>—</td> </tr> <tr> <td>0,50</td><td>1,77</td><td>1,77</td><td>1,77</td><td>1,77</td><td>1,77</td><td>1,77</td><td>—</td><td>—</td><td>—</td><td>—</td> </tr> <tr> <td>0,55</td><td>2,26</td><td>2,26</td><td>2,26</td><td>2,26</td><td>2,26</td><td>2,26</td><td>—</td><td>—</td><td>—</td><td>—</td> </tr> <tr> <td>0,60</td><td>2,74</td><td>2,74</td><td>2,74</td><td>2,74</td><td>2,74</td><td>2,74</td><td>—</td><td>—</td><td>—</td><td>—</td> </tr> <tr> <td>0,63</td><td>3,03</td><td>3,03</td><td>3,03</td><td>3,03</td><td>3,03</td><td>3,03</td><td>—</td><td>—</td><td>—</td><td>—</td> </tr> <tr> <td>0,75</td><td>3,92</td><td>4,20</td><td>4,20</td><td>4,20</td><td>4,20</td><td>4,20</td><td>—</td><td>—</td><td>—</td><td>—</td> </tr> <tr> <td>0,88</td><td>3,92</td><td>4,32</td><td>4,32</td><td>4,32</td><td>4,32</td><td>4,32</td><td>—</td><td>—</td><td>—</td><td>—</td> </tr> <tr> <td>1,00</td><td>3,92</td><td>4,44</td><td>4,44</td><td>4,44</td><td>4,44</td><td>4,44</td><td>—</td><td>—</td><td>—</td><td>—</td> </tr> <tr> <td rowspan="6"><math>u</math> [mm]</td> <td>40</td><td>3,0</td><td>3,0</td><td>3,0</td><td>3,0</td><td>3,0</td><td>3,0</td><td>—</td><td>—</td><td>—</td><td>—</td> </tr> <tr> <td>50</td><td>4,5</td><td>4,5</td><td>4,5</td><td>4,5</td><td>4,5</td><td>4,5</td><td>—</td><td>—</td><td>—</td><td>—</td> </tr> <tr> <td>60</td><td>6,0</td><td>6,0</td><td>6,0</td><td>6,0</td><td>6,0</td><td>6,0</td><td>—</td><td>—</td><td>—</td><td>—</td> </tr> <tr> <td>70</td><td>7,4</td><td>7,4</td><td>7,4</td><td>7,4</td><td>7,4</td><td>7,4</td><td>—</td><td>—</td><td>—</td><td>—</td> </tr> <tr> <td>80</td><td>8,8</td><td>8,8</td><td>8,8</td><td>8,8</td><td>8,8</td><td>8,8</td><td>—</td><td>—</td><td>—</td><td>—</td> </tr> <tr> <td>90</td><td>10,1</td><td>10,1</td><td>10,1</td><td>10,1</td><td>10,1</td><td>10,1</td><td>—</td><td>—</td><td>—</td><td>—</td> </tr> <tr> <td><math>\geq 100</math></td><td>11,5</td><td>11,5</td><td>11,5</td><td>11,5</td><td>11,5</td><td>11,5</td><td>—</td><td>—</td><td>—</td><td>—</td> </tr> <tr> <td><math>N_{R,k,II}</math> [kN]</td> <td>3,92</td><td>4,92</td><td>5,91</td><td>6,22</td><td>6,52</td><td>6,52</td><td>—</td><td>—</td><td>—</td><td>—</td> </tr> </tbody> </table>	$t_{N1}, t_{N2}, d, D$ [mm]	$t_{II}$ [mm]										4,00	5,00	6,00	7,00	8,00	$\geq 10,0$	—	—	—	—	$V_{R,k}$ [kN]	0,40	0,82	0,82	0,82	0,82	0,82	0,82	—	—	—	—	0,50	0,93	1,12	1,30	1,30	1,30	1,30	—	—	—	—	0,55	1,12	1,28	1,44	1,44	1,44	1,44	—	—	—	—	0,60	1,31	1,45	1,58	1,58	1,58	1,58	—	—	—	—	0,63	1,42	1,54	1,66	1,66	1,66	1,66	—	—	—	—	0,75	1,88	1,94	2,00	2,00	2,00	2,00	—	—	—	—	0,88	2,33	2,57	2,81	2,81	2,81	2,81	—	—	—	—	1,00	2,74	3,15	3,56	3,56	3,56	3,56	—	—	—	—	$N_{R,k}$ [kN]	0,40	1,65	1,65	1,65	1,65	1,65	1,65	—	—	—	—	0,50	1,77	1,77	1,77	1,77	1,77	1,77	—	—	—	—	0,55	2,26	2,26	2,26	2,26	2,26	2,26	—	—	—	—	0,60	2,74	2,74	2,74	2,74	2,74	2,74	—	—	—	—	0,63	3,03	3,03	3,03	3,03	3,03	3,03	—	—	—	—	0,75	3,92	4,20	4,20	4,20	4,20	4,20	—	—	—	—	0,88	3,92	4,32	4,32	4,32	4,32	4,32	—	—	—	—	1,00	3,92	4,44	4,44	4,44	4,44	4,44	—	—	—	—	$u$ [mm]	40	3,0	3,0	3,0	3,0	3,0	3,0	—	—	—	—	50	4,5	4,5	4,5	4,5	4,5	4,5	—	—	—	—	60	6,0	6,0	6,0	6,0	6,0	6,0	—	—	—	—	70	7,4	7,4	7,4	7,4	7,4	7,4	—	—	—	—	80	8,8	8,8	8,8	8,8	8,8	8,8	—	—	—	—	90	10,1	10,1	10,1	10,1	10,1	10,1	—	—	—	—	$\geq 100$	11,5	11,5	11,5	11,5	11,5	11,5	—	—	—	—	$N_{R,k,II}$ [kN]	3,92	4,92	5,91	6,22	6,52	6,52	—	—	—	—	<p>No additional regulations.</p>
$t_{N1}, t_{N2}, d, D$ [mm]		$t_{II}$ [mm]																																																																																																																																																																																																																																																																																															
	4,00	5,00	6,00	7,00	8,00	$\geq 10,0$	—	—	—	—																																																																																																																																																																																																																																																																																							
$V_{R,k}$ [kN]	0,40	0,82	0,82	0,82	0,82	0,82	0,82	—	—	—	—																																																																																																																																																																																																																																																																																						
	0,50	0,93	1,12	1,30	1,30	1,30	1,30	—	—	—	—																																																																																																																																																																																																																																																																																						
	0,55	1,12	1,28	1,44	1,44	1,44	1,44	—	—	—	—																																																																																																																																																																																																																																																																																						
	0,60	1,31	1,45	1,58	1,58	1,58	1,58	—	—	—	—																																																																																																																																																																																																																																																																																						
	0,63	1,42	1,54	1,66	1,66	1,66	1,66	—	—	—	—																																																																																																																																																																																																																																																																																						
	0,75	1,88	1,94	2,00	2,00	2,00	2,00	—	—	—	—																																																																																																																																																																																																																																																																																						
	0,88	2,33	2,57	2,81	2,81	2,81	2,81	—	—	—	—																																																																																																																																																																																																																																																																																						
	1,00	2,74	3,15	3,56	3,56	3,56	3,56	—	—	—	—																																																																																																																																																																																																																																																																																						
$N_{R,k}$ [kN]	0,40	1,65	1,65	1,65	1,65	1,65	1,65	—	—	—	—																																																																																																																																																																																																																																																																																						
	0,50	1,77	1,77	1,77	1,77	1,77	1,77	—	—	—	—																																																																																																																																																																																																																																																																																						
	0,55	2,26	2,26	2,26	2,26	2,26	2,26	—	—	—	—																																																																																																																																																																																																																																																																																						
	0,60	2,74	2,74	2,74	2,74	2,74	2,74	—	—	—	—																																																																																																																																																																																																																																																																																						
	0,63	3,03	3,03	3,03	3,03	3,03	3,03	—	—	—	—																																																																																																																																																																																																																																																																																						
	0,75	3,92	4,20	4,20	4,20	4,20	4,20	—	—	—	—																																																																																																																																																																																																																																																																																						
	0,88	3,92	4,32	4,32	4,32	4,32	4,32	—	—	—	—																																																																																																																																																																																																																																																																																						
	1,00	3,92	4,44	4,44	4,44	4,44	4,44	—	—	—	—																																																																																																																																																																																																																																																																																						
$u$ [mm]	40	3,0	3,0	3,0	3,0	3,0	3,0	—	—	—	—																																																																																																																																																																																																																																																																																						
	50	4,5	4,5	4,5	4,5	4,5	4,5	—	—	—	—																																																																																																																																																																																																																																																																																						
	60	6,0	6,0	6,0	6,0	6,0	6,0	—	—	—	—																																																																																																																																																																																																																																																																																						
	70	7,4	7,4	7,4	7,4	7,4	7,4	—	—	—	—																																																																																																																																																																																																																																																																																						
	80	8,8	8,8	8,8	8,8	8,8	8,8	—	—	—	—																																																																																																																																																																																																																																																																																						
	90	10,1	10,1	10,1	10,1	10,1	10,1	—	—	—	—																																																																																																																																																																																																																																																																																						
$\geq 100$	11,5	11,5	11,5	11,5	11,5	11,5	—	—	—	—																																																																																																																																																																																																																																																																																							
$N_{R,k,II}$ [kN]	3,92	4,92	5,91	6,22	6,52	6,52	—	—	—	—																																																																																																																																																																																																																																																																																							
<p>Self drilling screw</p> <p>Hilti S-CD 75 GS 5,5 x L                  Hilti S-CD 75 GSS 5,5 x L                  with hexagon head and sealing washer <math>\varnothing 22</math> mm</p> <p>Annex 25</p>																																																																																																																																																																																																																																																																																																	

Annex 15:  
ETA-13/0179, Annex 26

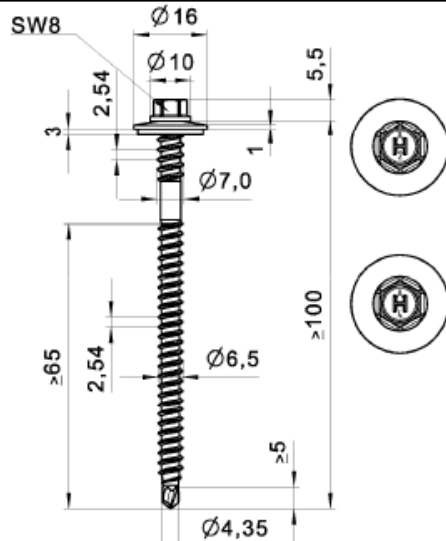

**Material:**  
 Fastener: stainless Steel (1.4301, 1.4401, 1.4571) - EN 10088  
 Washer: stainless Steel (1.4301) - EN 10088  
 Component I: S280GD, S320GD - EN 10346  
 Component II: Structural timber - EN 14081

**Drilling capacity:**  $\Sigma t_i \leq 2,00$  mm

**Timber substructures:**  
 performance determined with

$M_{y,Rk} = 9,741$  Nm  
 $f_{ax,k} = 10,769$  N/mm<sup>2</sup> for  $l_{ef} \geq 50,0$  mm

$t_{N1}, t_{N2}$ [mm]	d, D [mm]									
	30	40	50	60	70	80	100	120	≥ 140	
$V_{R,I,k}$ [kN]	0,40	0,62	0,62	0,62	0,62	0,62	0,62	0,62	0,62	0,62
	0,50	0,98	0,98	0,98	0,98	0,98	0,98	0,98	0,98	0,98
	0,55	1,15	1,15	1,15	1,15	1,15	1,15	1,15	1,15	1,15
	0,60	1,37	1,37	1,37	1,37	1,37	1,37	1,37	1,37	1,37
	0,63	1,50	1,50	1,50	1,50	1,50	1,50	1,50	1,50	1,50
	0,75	2,17	2,17	2,17	2,17	2,17	2,17	2,17	2,17	2,17
	0,88	2,17	2,17	2,17	2,17	2,17	2,17	2,17	2,17	2,17
	1,00	2,17	2,17	2,17	2,17	2,17	2,17	2,17	2,17	2,17
$N_{R,I,k}$ [kN]	0,40	—	—	—	—	—	—	—	—	—
	0,50	1,72	1,72	1,72	1,72	1,72	1,72	1,72	1,72	1,72
	0,55	1,96	1,96	1,96	1,96	1,96	1,96	1,96	1,96	1,96
	0,60	2,12	2,12	2,12	2,12	2,12	2,12	2,12	2,12	2,12
	0,63	2,21	2,21	2,21	2,21	2,21	2,21	2,21	2,21	2,21
	0,75	2,73	2,73	2,73	2,73	2,73	2,73	2,73	2,73	2,73
	0,88	3,32	3,32	3,32	3,32	3,32	3,32	3,32	3,32	3,32
	1,00	3,50	3,50	3,50	3,50	3,50	3,50	3,50	3,50	3,50
u [mm]	—	5,0	7,0	9,0	11,0	13,0	18,0	18,0	18,0	
$N_{R,k,II}$ [kN]	3,15	3,15	3,15	3,15	3,15	3,15	3,15	3,15	3,15	

If component  $t_{N1}$  resp.  $t_{N2}$  is made of S320GD the grey highlighted values may be increased by 8,3%.  
 The values listed above in dependence on the screw-in length  $l_{ef}$  and the values  $N_{R,k,II}$  are valid for  $k_{mod} = 0,90$  and timber strength grade C24 ( $\rho_a = 350$  kg/m<sup>3</sup>). For other combinations of  $k_{mod}$  and timber strength grades see Annex 3.

Self drilling screw	Annex 26
Hilti S-CDW 51 S 6,5 x L Hilti S-CDW 51 SS 6,5 x L with hexagon head and sealing washer Ø16 mm	

Annex 16:  
ETA-13/0179, Annex 27

	<p><b>Material:</b>  <b>Fastener:</b> stainless Steel (1.4301, 1.4401, 1.4571) - EN 10088  <b>Washer:</b> stainless Steel (1.4301) - EN 10088  <b>Component I:</b> S280GD, S320GD - EN 10346  <b>Component II:</b> Structural timber - EN 14081</p>																																																																																																																																																																																																																	
	<p><b>Drilling capacity:</b> <math>\Sigma t_i \leq 2,00</math> mm</p>																																																																																																																																																																																																																	
	<p><b>Timber substructures:</b>          performance determined with  <math>M_{y,Rk} = 9,741</math> Nm  <math>f_{ax,k} = 10,769</math> N/mm<sup>2</sup> for <math>l_{ef} \geq 50,0</math> mm</p>																																																																																																																																																																																																																	
<table border="1"> <thead> <tr> <th rowspan="2"><math>t_{N1}, t_{N2}</math> [mm]</th> <th colspan="9">d, D [mm]</th> </tr> <tr> <th>30</th> <th>40</th> <th>50</th> <th>60</th> <th>70</th> <th>80</th> <th>100</th> <th>120</th> <th><math>\geq 140</math></th> </tr> </thead> <tbody> <tr> <td rowspan="8"><math>V_{R,I,k}</math> [kN]</td> <td>0,40</td><td>0,62</td><td>0,62</td><td>0,62</td><td>0,62</td><td>0,62</td><td>0,62</td><td>0,62</td><td>0,62</td><td>0,62</td> </tr> <tr> <td>0,50</td><td>0,98</td><td>0,98</td><td>0,98</td><td>0,98</td><td>0,98</td><td>0,98</td><td>0,98</td><td>0,98</td><td>0,98</td> </tr> <tr> <td>0,55</td><td>1,15</td><td>1,15</td><td>1,15</td><td>1,15</td><td>1,15</td><td>1,15</td><td>1,15</td><td>1,15</td><td>1,15</td> </tr> <tr> <td>0,60</td><td>1,37</td><td>1,37</td><td>1,37</td><td>1,37</td><td>1,37</td><td>1,37</td><td>1,37</td><td>1,37</td><td>1,37</td> </tr> <tr> <td>0,63</td><td>1,50</td><td>1,50</td><td>1,50</td><td>1,50</td><td>1,50</td><td>1,50</td><td>1,50</td><td>1,50</td><td>1,50</td> </tr> <tr> <td>0,75</td><td>2,17</td><td>2,17</td><td>2,17</td><td>2,17</td><td>2,17</td><td>2,17</td><td>2,17</td><td>2,17</td><td>2,17</td> </tr> <tr> <td>0,88</td><td>2,17</td><td>2,17</td><td>2,17</td><td>2,17</td><td>2,17</td><td>2,17</td><td>2,17</td><td>2,17</td><td>2,17</td> </tr> <tr> <td>1,00</td><td>2,17</td><td>2,17</td><td>2,17</td><td>2,17</td><td>2,17</td><td>2,17</td><td>2,17</td><td>2,17</td><td>2,17</td> </tr> <tr> <td rowspan="8"><math>N_{R,I,k}</math> [kN]</td> <td>0,40</td><td>—</td><td>—</td><td>—</td><td>—</td><td>—</td><td>—</td><td>—</td><td>—</td><td>—</td> </tr> <tr> <td>0,50</td><td>2,60</td><td>2,60</td><td>2,60</td><td>2,60</td><td>2,60</td><td>2,60</td><td>2,60</td><td>2,60</td><td>2,60</td> </tr> <tr> <td>0,55</td><td>3,10</td><td>3,10</td><td>3,10</td><td>3,10</td><td>3,10</td><td>3,10</td><td>3,10</td><td>3,10</td><td>3,10</td> </tr> <tr> <td>0,60</td><td>3,35</td><td>3,35</td><td>3,35</td><td>3,35</td><td>3,35</td><td>3,35</td><td>3,35</td><td>3,35</td><td>3,35</td> </tr> <tr> <td>0,63</td><td>3,50</td><td>3,50</td><td>3,50</td><td>3,50</td><td>3,50</td><td>3,50</td><td>3,50</td><td>3,50</td><td>3,50</td> </tr> <tr> <td>0,75</td><td>3,50</td><td>3,50</td><td>3,50</td><td>3,50</td><td>3,50</td><td>3,50</td><td>3,50</td><td>3,50</td><td>3,50</td> </tr> <tr> <td>0,88</td><td>3,50</td><td>3,50</td><td>3,50</td><td>3,50</td><td>3,50</td><td>3,50</td><td>3,50</td><td>3,50</td><td>3,50</td> </tr> <tr> <td>1,00</td><td>3,50</td><td>3,50</td><td>3,50</td><td>3,50</td><td>3,50</td><td>3,50</td><td>3,50</td><td>3,50</td><td>3,50</td> </tr> <tr> <td>u [mm]</td> <td>—</td><td>5,0</td><td>7,0</td><td>9,0</td><td>11,0</td><td>13,0</td><td>18,0</td><td>18,0</td><td>18,0</td> </tr> <tr> <td><math>N_{R,k,II}</math> [kN]</td> <td>3,15</td><td>3,15</td><td>3,15</td><td>3,15</td><td>3,15</td><td>3,15</td><td>3,15</td><td>3,15</td><td>3,15</td> </tr> </tbody> </table>										$t_{N1}, t_{N2}$ [mm]	d, D [mm]									30	40	50	60	70	80	100	120	$\geq 140$	$V_{R,I,k}$ [kN]	0,40	0,62	0,62	0,62	0,62	0,62	0,62	0,62	0,62	0,62	0,50	0,98	0,98	0,98	0,98	0,98	0,98	0,98	0,98	0,98	0,55	1,15	1,15	1,15	1,15	1,15	1,15	1,15	1,15	1,15	0,60	1,37	1,37	1,37	1,37	1,37	1,37	1,37	1,37	1,37	0,63	1,50	1,50	1,50	1,50	1,50	1,50	1,50	1,50	1,50	0,75	2,17	2,17	2,17	2,17	2,17	2,17	2,17	2,17	2,17	0,88	2,17	2,17	2,17	2,17	2,17	2,17	2,17	2,17	2,17	1,00	2,17	2,17	2,17	2,17	2,17	2,17	2,17	2,17	2,17	$N_{R,I,k}$ [kN]	0,40	—	—	—	—	—	—	—	—	—	0,50	2,60	2,60	2,60	2,60	2,60	2,60	2,60	2,60	2,60	0,55	3,10	3,10	3,10	3,10	3,10	3,10	3,10	3,10	3,10	0,60	3,35	3,35	3,35	3,35	3,35	3,35	3,35	3,35	3,35	0,63	3,50	3,50	3,50	3,50	3,50	3,50	3,50	3,50	3,50	0,75	3,50	3,50	3,50	3,50	3,50	3,50	3,50	3,50	3,50	0,88	3,50	3,50	3,50	3,50	3,50	3,50	3,50	3,50	3,50	1,00	3,50	3,50	3,50	3,50	3,50	3,50	3,50	3,50	3,50	u [mm]	—	5,0	7,0	9,0	11,0	13,0	18,0	18,0	18,0	$N_{R,k,II}$ [kN]	3,15	3,15	3,15	3,15	3,15	3,15	3,15	3,15	3,15
$t_{N1}, t_{N2}$ [mm]	d, D [mm]																																																																																																																																																																																																																	
	30	40	50	60	70	80	100	120	$\geq 140$																																																																																																																																																																																																									
$V_{R,I,k}$ [kN]	0,40	0,62	0,62	0,62	0,62	0,62	0,62	0,62	0,62	0,62																																																																																																																																																																																																								
	0,50	0,98	0,98	0,98	0,98	0,98	0,98	0,98	0,98	0,98																																																																																																																																																																																																								
	0,55	1,15	1,15	1,15	1,15	1,15	1,15	1,15	1,15	1,15																																																																																																																																																																																																								
	0,60	1,37	1,37	1,37	1,37	1,37	1,37	1,37	1,37	1,37																																																																																																																																																																																																								
	0,63	1,50	1,50	1,50	1,50	1,50	1,50	1,50	1,50	1,50																																																																																																																																																																																																								
	0,75	2,17	2,17	2,17	2,17	2,17	2,17	2,17	2,17	2,17																																																																																																																																																																																																								
	0,88	2,17	2,17	2,17	2,17	2,17	2,17	2,17	2,17	2,17																																																																																																																																																																																																								
	1,00	2,17	2,17	2,17	2,17	2,17	2,17	2,17	2,17	2,17																																																																																																																																																																																																								
$N_{R,I,k}$ [kN]	0,40	—	—	—	—	—	—	—	—	—																																																																																																																																																																																																								
	0,50	2,60	2,60	2,60	2,60	2,60	2,60	2,60	2,60	2,60																																																																																																																																																																																																								
	0,55	3,10	3,10	3,10	3,10	3,10	3,10	3,10	3,10	3,10																																																																																																																																																																																																								
	0,60	3,35	3,35	3,35	3,35	3,35	3,35	3,35	3,35	3,35																																																																																																																																																																																																								
	0,63	3,50	3,50	3,50	3,50	3,50	3,50	3,50	3,50	3,50																																																																																																																																																																																																								
	0,75	3,50	3,50	3,50	3,50	3,50	3,50	3,50	3,50	3,50																																																																																																																																																																																																								
	0,88	3,50	3,50	3,50	3,50	3,50	3,50	3,50	3,50	3,50																																																																																																																																																																																																								
	1,00	3,50	3,50	3,50	3,50	3,50	3,50	3,50	3,50	3,50																																																																																																																																																																																																								
u [mm]	—	5,0	7,0	9,0	11,0	13,0	18,0	18,0	18,0																																																																																																																																																																																																									
$N_{R,k,II}$ [kN]	3,15	3,15	3,15	3,15	3,15	3,15	3,15	3,15	3,15																																																																																																																																																																																																									
<p>If component <math>t_{N1}</math> resp. <math>t_{N2}</math> is made of S320GD the grey highlighted values may be increased by 8,3%.          The values listed above in dependence on the screw-in length <math>l_{ef}</math> and the values <math>N_{R,k,II}</math> are valid for <math>k_{mod} = 0,90</math> and timber strength grade C24 (<math>\rho_a = 350</math> kg/m<sup>3</sup>). For other combinations of <math>k_{mod}</math> and timber strength grades see Annex 3.</p>																																																																																																																																																																																																																		
<p>Self drilling screw</p>								<p>Annex 27</p>																																																																																																																																																																																																										
<p>Hilti S-CDW 61 S 6,5 x L          Hilti S-CDW 61 SS 6,5 x L          Hilti S-CDW 71 S 6,5 x L          Hilti S-CDW 71 SS 6,5 x L          with hexagon head and sealing washer <math>\geq \text{Ø}19</math> mm</p>																																																																																																																																																																																																																		